

Factsheet

A1-A2

DUPLEX

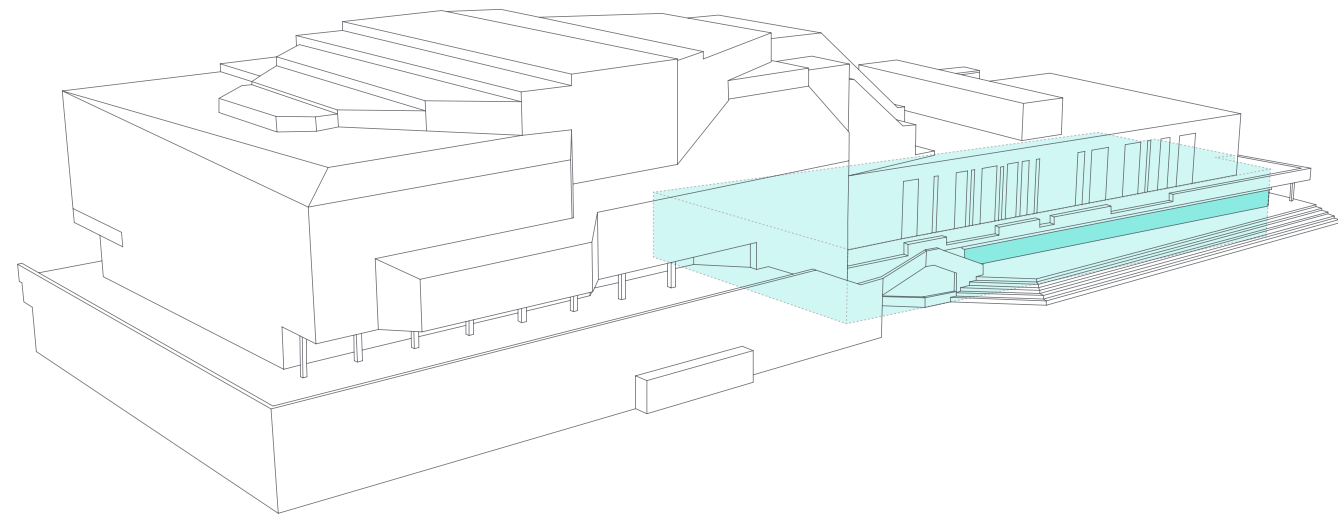

A2

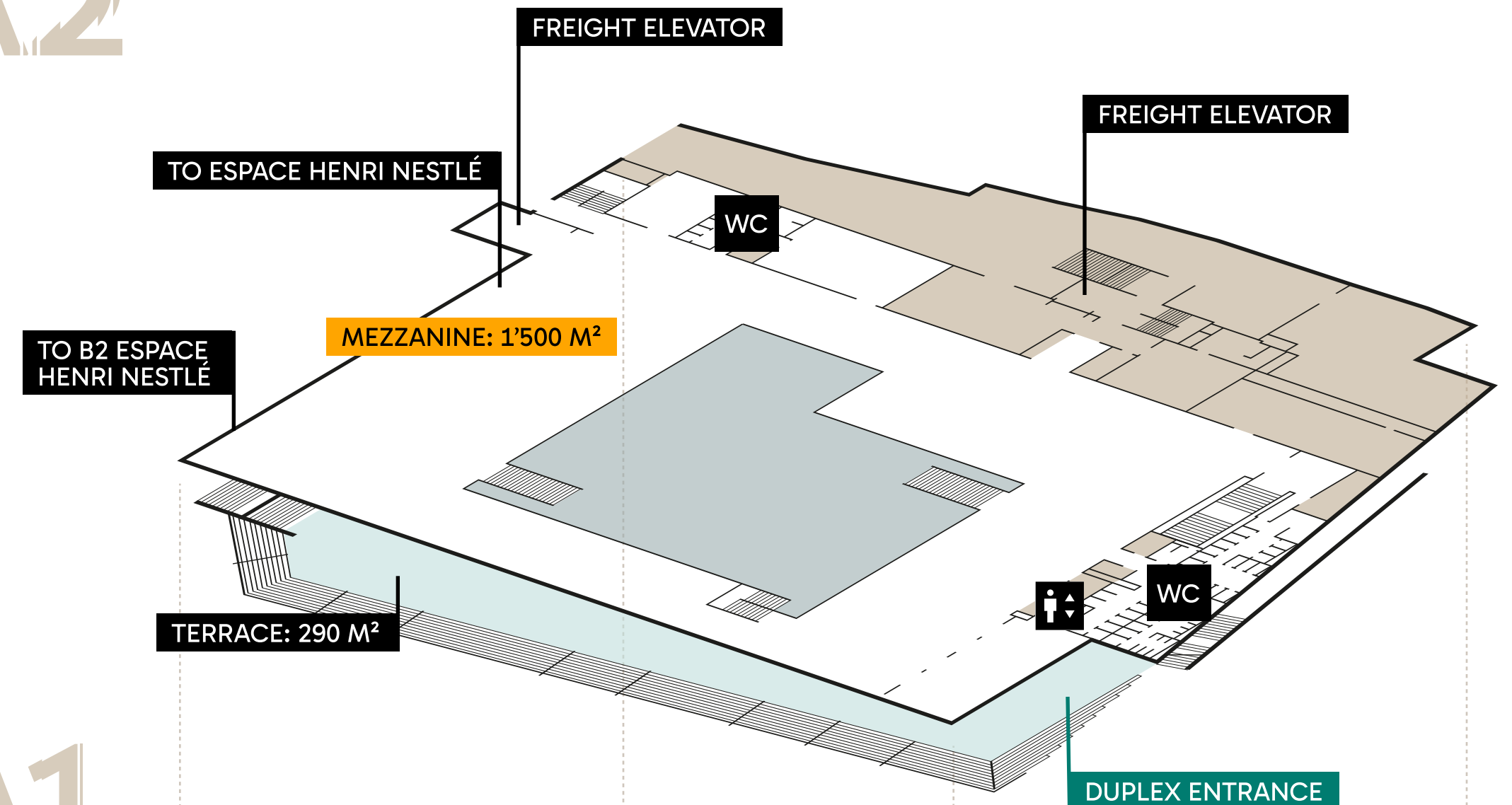

A1

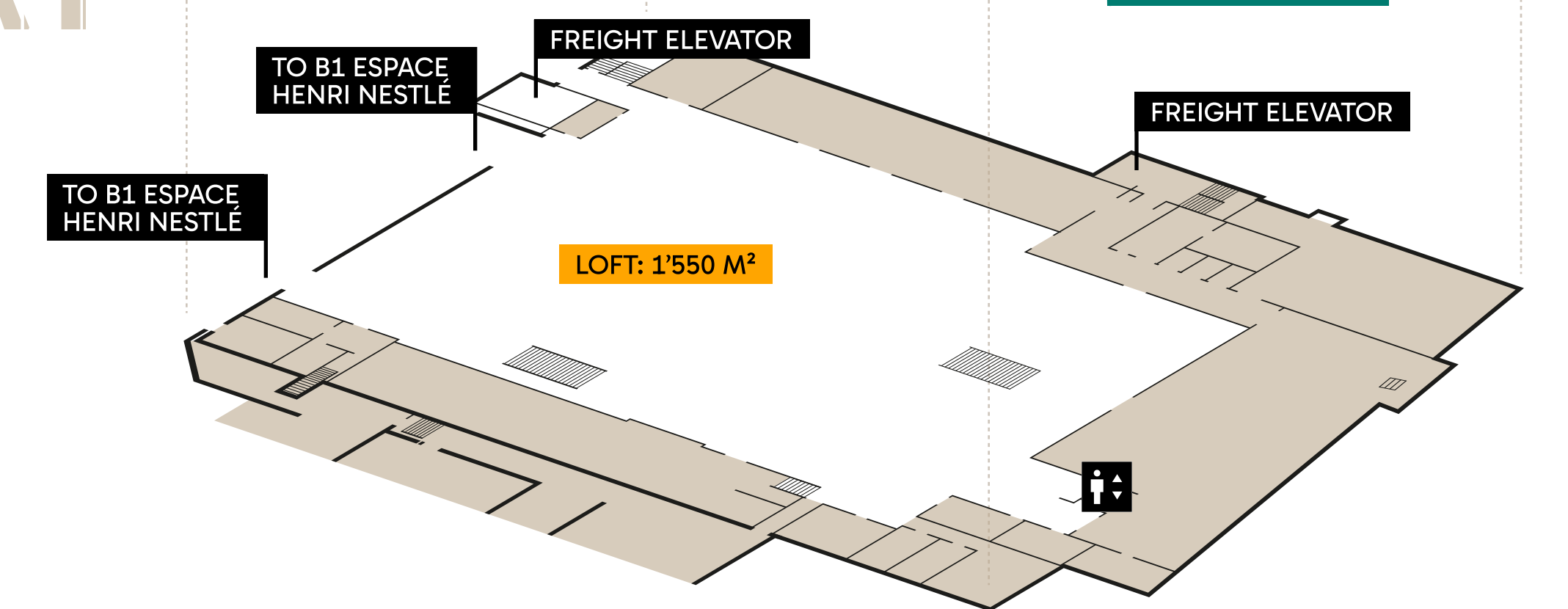

■ Outdoor areas (terraces, balconies) ■ Gap on the lower floor ■ Zone 2M2C (offices, technical facilities, storage)

A Space with a Spectacular View

This event space was designed to inspire and connect. The DUPLEX unfolds over two levels, offering exceptional flexibility and modularity.

Its expansive floor-to-ceiling windows create a constant dialogue between the interior and the unique Montreux surroundings, inviting the lake and mountains to become an integral part of every event, enhanced by a vast 290 m² terrace.

Versatility & Cool Sophistication

Designed to meet the most diverse requirements: trade fairs and exhibitions, corporate events, networking cocktails, DJ concerts, international conferences, product launches, gala evenings, prestige events.

TECHNICAL SPECIFICATIONS

 Level 1–2 Miles Davis Building

 **Surface area:** 3,058 m²

 **Ceiling height:** 230 - 520 cm

 **Flooring:** resin concrete

 **Floor load capacity:**
500kg/m² (Loft)
400kg/m² (Mezzanine)

 Lift

 PRM access

 **Freight elevators:** 2

1 Max 6T, loading dock access (Stravinski Building)

2 Max 3T, road access (Stravinski Building)

 Dedicated direct access from docks and street

 WiFi on demand

 Heating, ventilation, air conditioning

 Dynamic signage

 Natural daylight

CAPACITIES

 **Theatre:** /

 **U-Shape:** /

 **Classroom:** /

 **Cabaret:** /

 **Banquet:** 840

 **Cocktail:** 840

 **Concert:** 840

 **Exhibition:** 3,058 m²

TERRACE

 **Terrace area:** 287 m²

 **Height:** Uncovered

 **Capacity (cocktail):** 220

A3

MILES DAVIS HALL

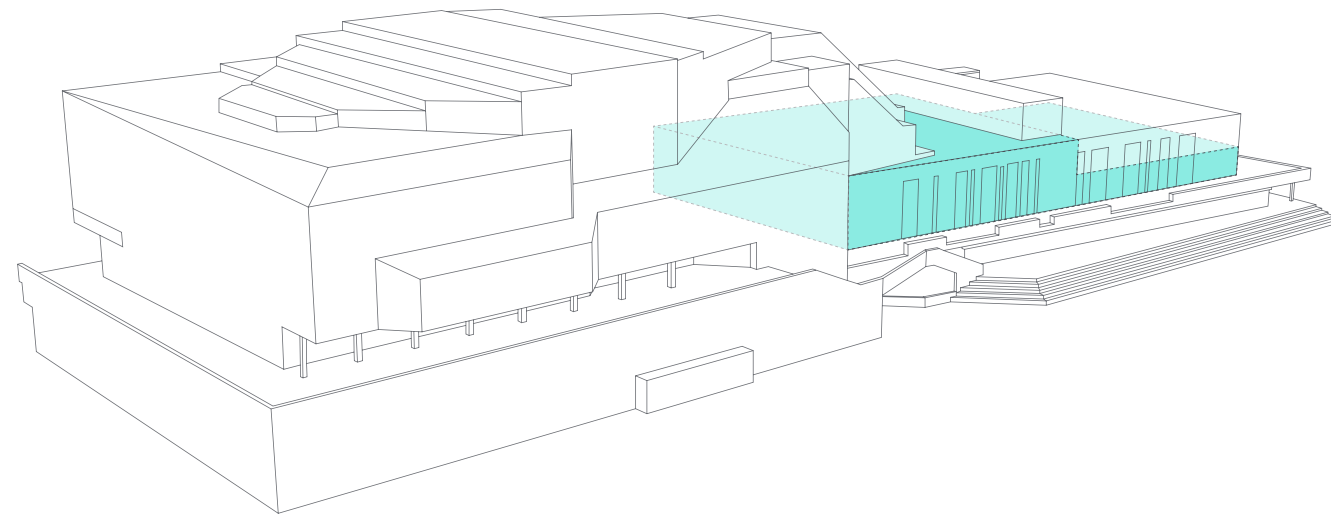

A3

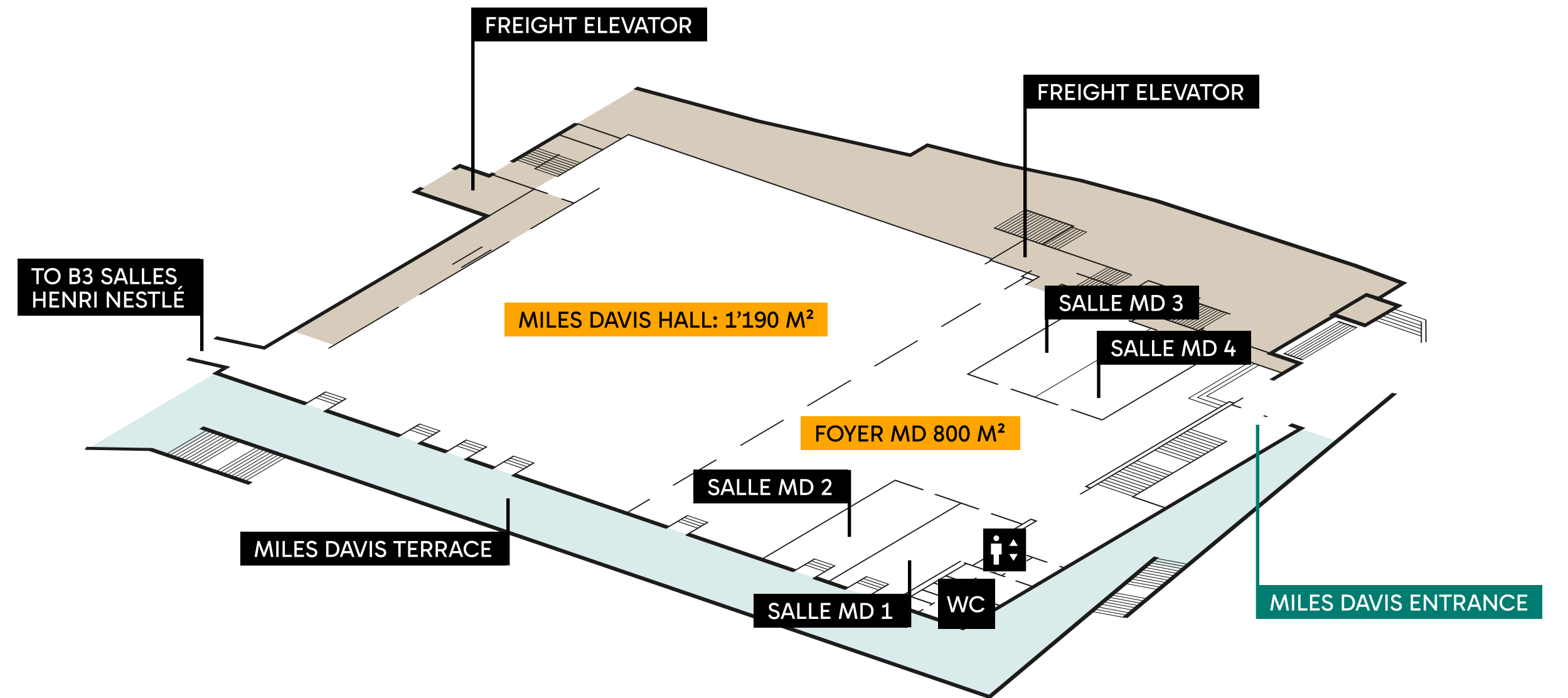

■ Outdoor areas (terraces, balconies) ■ Gap on the lower floor ■ Zone 2M2C (offices, technical facilities, storage)

A Legendary Space, a Timeless Inspiration

Just as Miles Davis improvised new sonic territories, this space offers true architectural compositions.

Directly accessible from the quay, the Hall becomes an instrument where every configuration is possible — each event a unique performance. Like Miles' jazz, this venue is a territory of freedom.

Natural light plays as a subtle accompaniment, while the panorama of the lake and the Alps forms a permanent visual chorus.

Shared Harmony

(Miles Davis Hall & Upper Miles Davis Hall)

Whether in the Miles Davis Hall or its Upper space, you benefit from a perfectly orchestrated setting:

Modular rhythm of spaces, flexible event arrangements, natural light in counterpoint, panoramic views like a timeless standard, and technical connections in perfect harmony.

TECHNICAL SPECIFICATIONS

 Level 3 Miles Davis Building

 **Surface area:** 1,189 m²

 **Ceiling height:** 600 cm

 **Flooring:** carpet

 **Floor load capacity:** 400 kg/m²

 Lift

 PRM access

 **Freight elevators:** 2

1 Max 6T, loading dock access (Stravinski Building)

2 Max 2T, road access (Stravinski Building)

 Direct access from the street

 WiFi on demand

 Heating, ventilation, air conditioning

 Dynamic signage

CAPACITIES

 **Theatre:** 900

 **U-Shape:** 100

 **Classroom:** 600

 **Cabaret:** 357

 **Banquet:** 680 (510 with stage and foyer)

 **Cocktail:** 1000 (1680 with foyer)

 **Concert:** 2,000

 **Exhibition:** 1,189 m²

TERRACE

 **Terrace area:** 535 m²

 **Ceiling height:** Not covered

 **Capacities (cocktail):** 420

The Miles Davis foyer invites connection and inspiration.

With its own private entrance, direct terrace access, and breathtaking views over Lake Geneva, this modular space offers an intimate setting.

When combined with the Miles Davis Hall, it becomes a stage in its own right — a place where exchanges find their rhythm, ideas improvise their melody, and the spirit of Miles still lingers, inspiring.

TECHNICAL SPECIFICATIONS

 Level 3 Miles Davis Building

 **Surface area:** 803 m²

 **Modular space:** 4 rooms of 60 m² each

 **Ceiling height:** 290 cm

 **Flooring:** carpet

 **Floor load capacity:** 400 kg/m²

 Lift

 PRM access

 **Freight elevators:** 2

1 Max 6T, loading dock access (Stravinski Building)

2 Max 2T, Miles Davis Building

 Direct access from docks and central hall

 Power outlets and energy rails

 Ceiling power supply

 Ceiling rigging possibilities

TECHNICAL SPECIFICATIONS

 WiFi on demand

 Heating, ventilation, air conditioning

 Dynamic signage

CAPACITIES

 **Theatre:** 48 - 100

 **U-Shape:** 27 - 33

 **Classroom:** 20 - 50

 **Banquet:** Up to 400 with foyer

 **Cocktail:** Up to 700 with foyer

 **Exhibition:** 803 m²

TERRACE

 **Terrace area:** 535 m²

 **Ceiling height:** Not covered

 **Capacities (cocktail):** 420

A4

AGORA

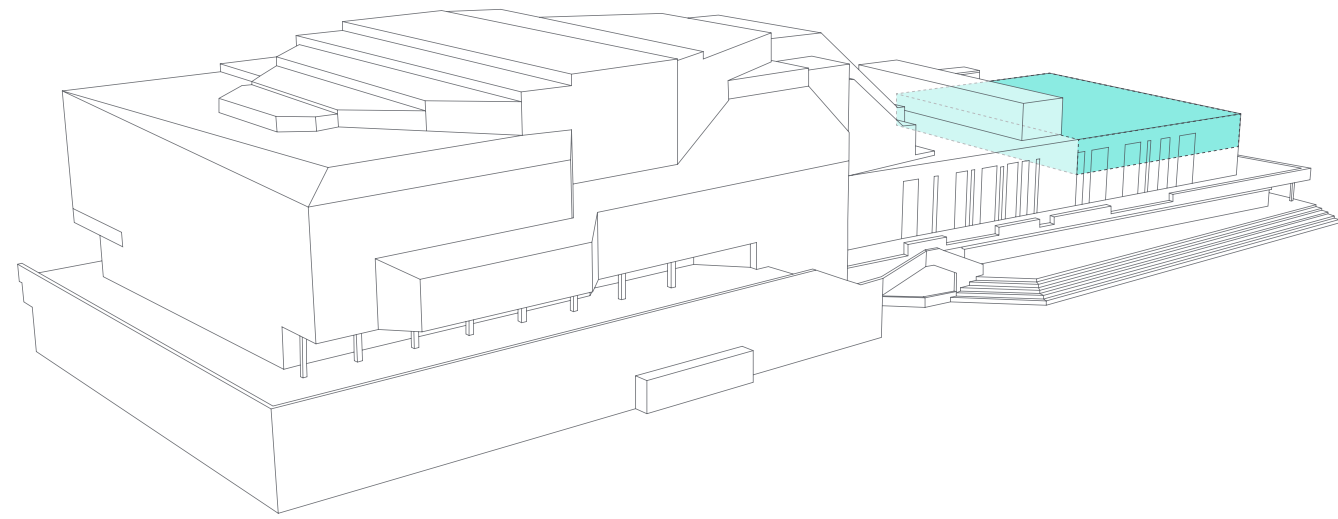

A4

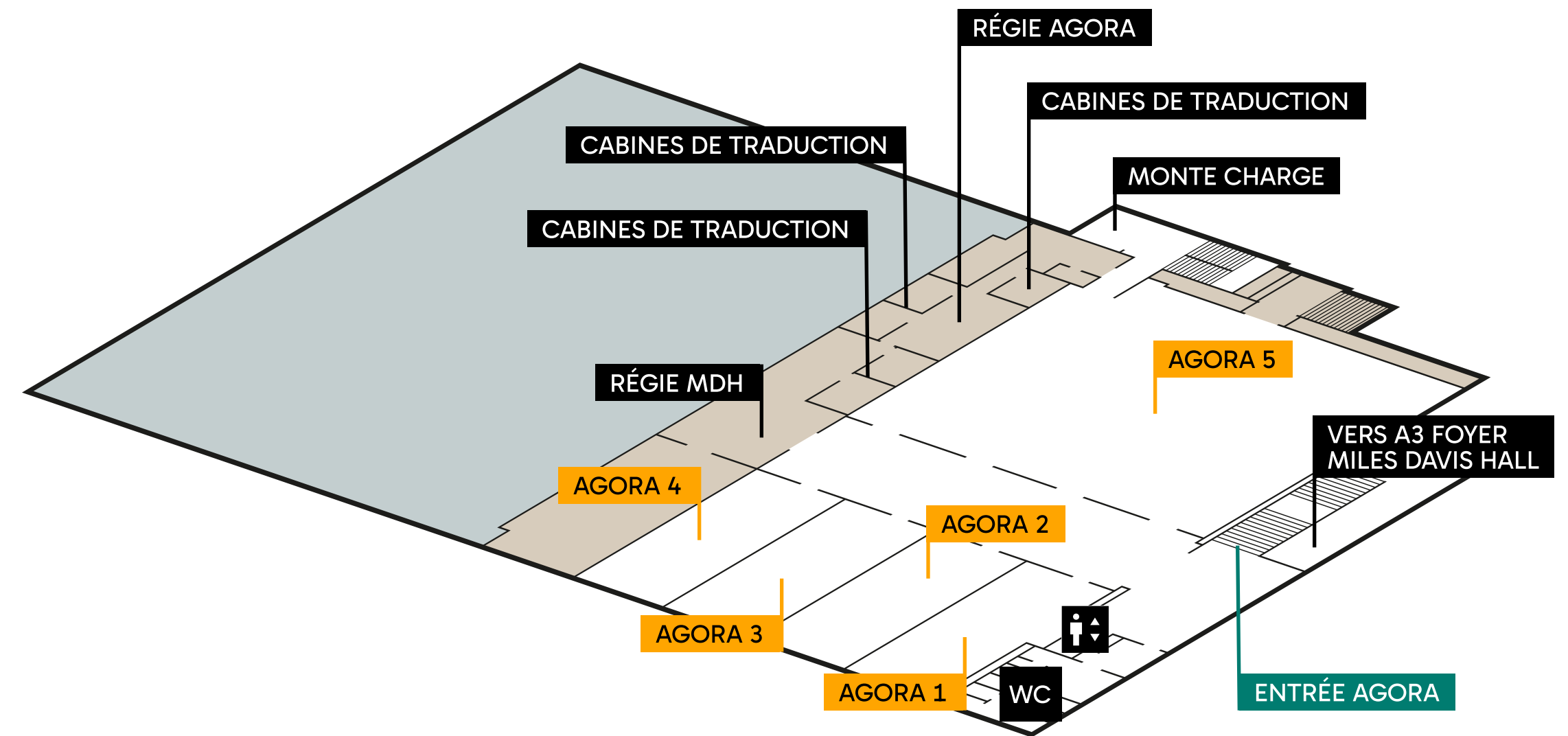

■ Zones extérieures (terrasses, balcons) ■ Vide sur étage inférieur ■ Zone 2M2C (bureaux, technique, stockage)

Event Types

Modular rhythm of spaces, flexible event layouts, natural light as a counterpoint, panoramic views like a timeless standard, and technical connections in perfect harmony.

Ideal for conferences, gala evenings, working sessions, or corporate events.

TECHNICAL SPECIFICATIONS

 Level 4 Miles Davis Building

 **Surface area:** 803 m²

 **Ceiling height:** 280 cm

 **Flooring:** carpet

 **Floor load capacity:** 400 kg/m²

 Lift

 PRM access

 **Freight elevator:** 1

1 Max 2T, Miles Davis Building

 WiFi on demand

 Heating, ventilation, air conditioning

 Dynamic signage

 Natural daylight (except enclosed room)

CAPACITIES

 **Theatre:** 48 - 300

 **U-Shape:** 27 - 70

 **Classroom:** 24 - 210

 **Cabaret:** 30 - 175

 **Banquet:** 50 - 450

 **Cocktail:** 50 - 600

 **Concert:** /

 **Exhibition:** 803 m²

B1

ESPACE HENRI NESTLÉ

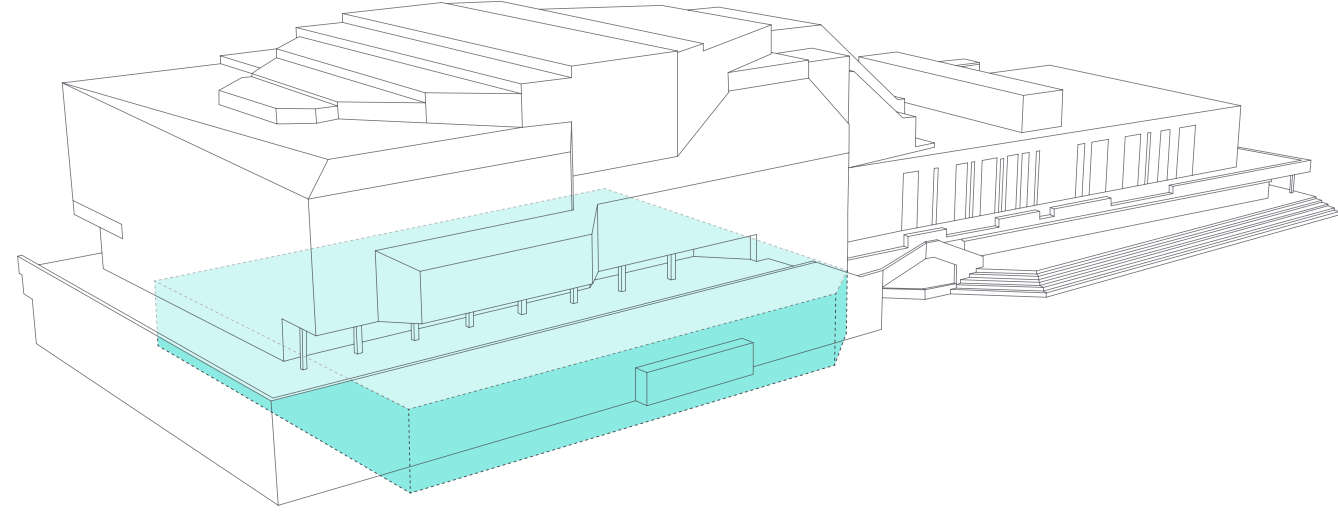

B2

B1

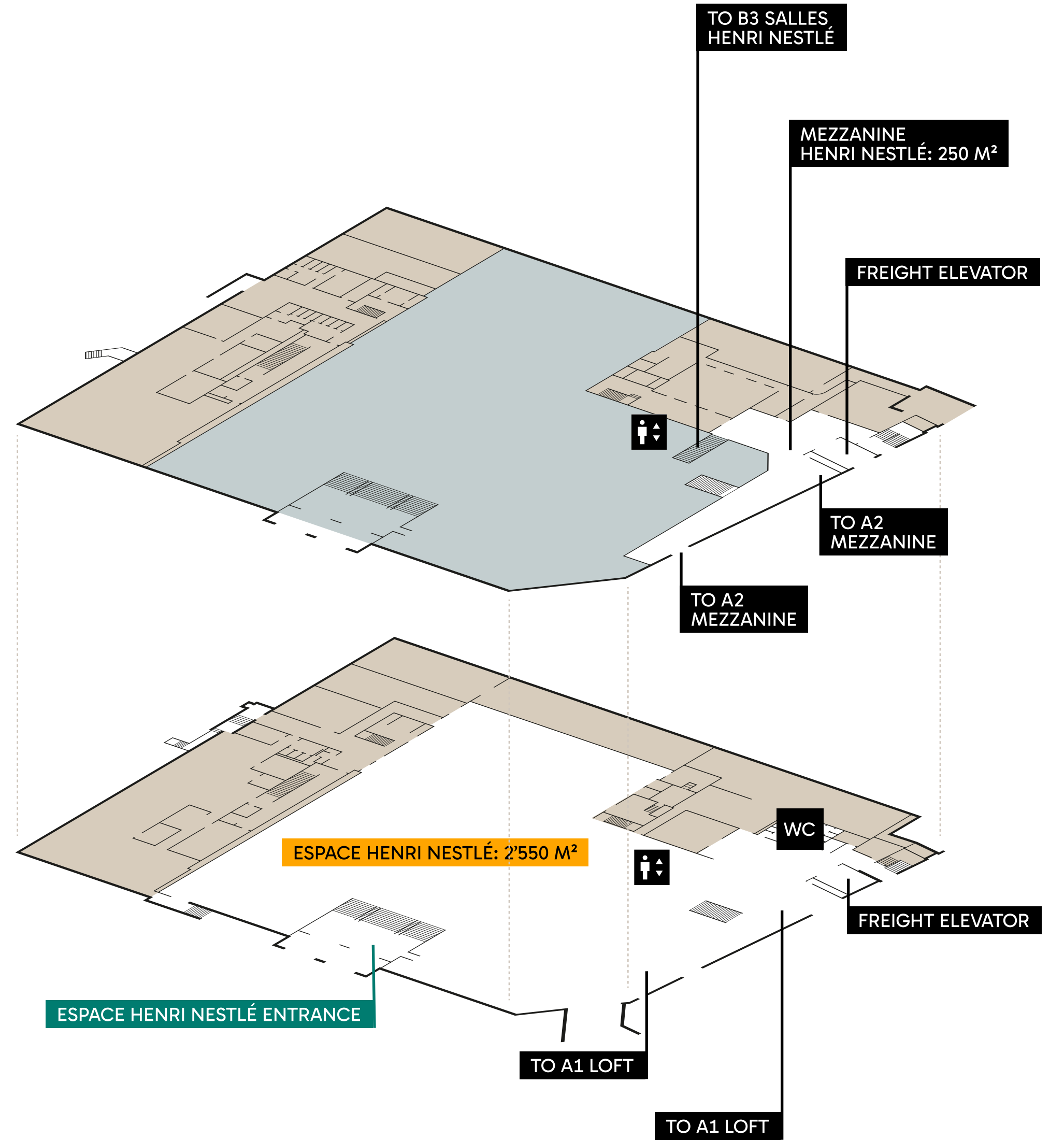

■ Outdoor areas (terraces, balconies)
 ■ Gap on the lower floor
 ■ Zone 2M2C (offices, technical facilities, storage)

The Alchemy of Encounters – A Laboratory of Events

Just as Henri Nestlé transformed simple ingredients into groundbreaking innovations, the Espace Henri Nestlé turns every event into a memorable experience.

With direct access from the quay, spectacular views, and a venue entirely open to creativity and limitless staging possibilities, this space offers a truly inspiring setting.

Event Staging

The space performs on every level: modular configurations, natural daylight, and a highly effective panoramic perspective.

Perfect for:

Exhibitions with stands, gala dinners, conferences, seminars, screenings, concerts, and more.

TECHNICAL SPECIFICATIONS

 Level 1-2 Stravinski Building

 **Surface area:** 2,570 m²

 **Terrace area:** 240 - 470 cm

 **Flooring:** Exposed concrete

 **Floor load capacity:** B1 500 kg/m², B2 400 kg/m²

 Lift

 PRM access

 **Freight elevators:** 1

1 Max 6T, loading dock access (Stravinski Building)

 Direct access from the docks

 WiFi on demand

 Heating, ventilation, air conditioning

 Dynamic signage

 Natural daylight

CAPACITIES

 **Theatre:** TBC

 **U-Shape:** /

 **Classroom:** TBC

 **Cabaret:** TBC

 **Banquet:** TBC

 **Cocktail:** TBC

 **Concert:** TBC

 **Exhibition:** 2,570 m²

B3

SALLES HENRI NESTLÉ

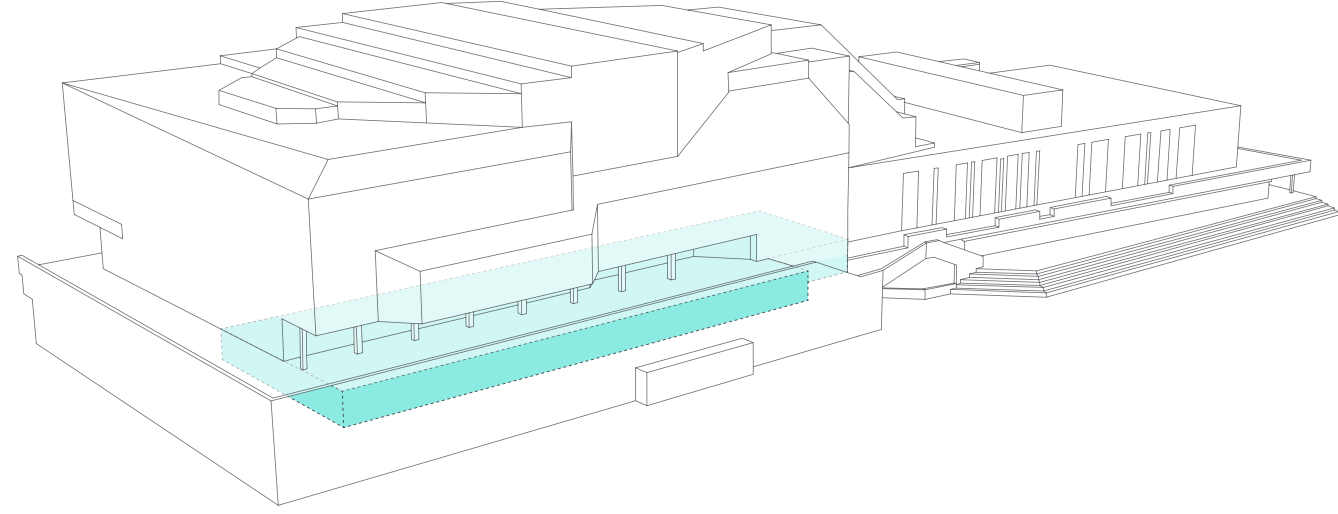

B3

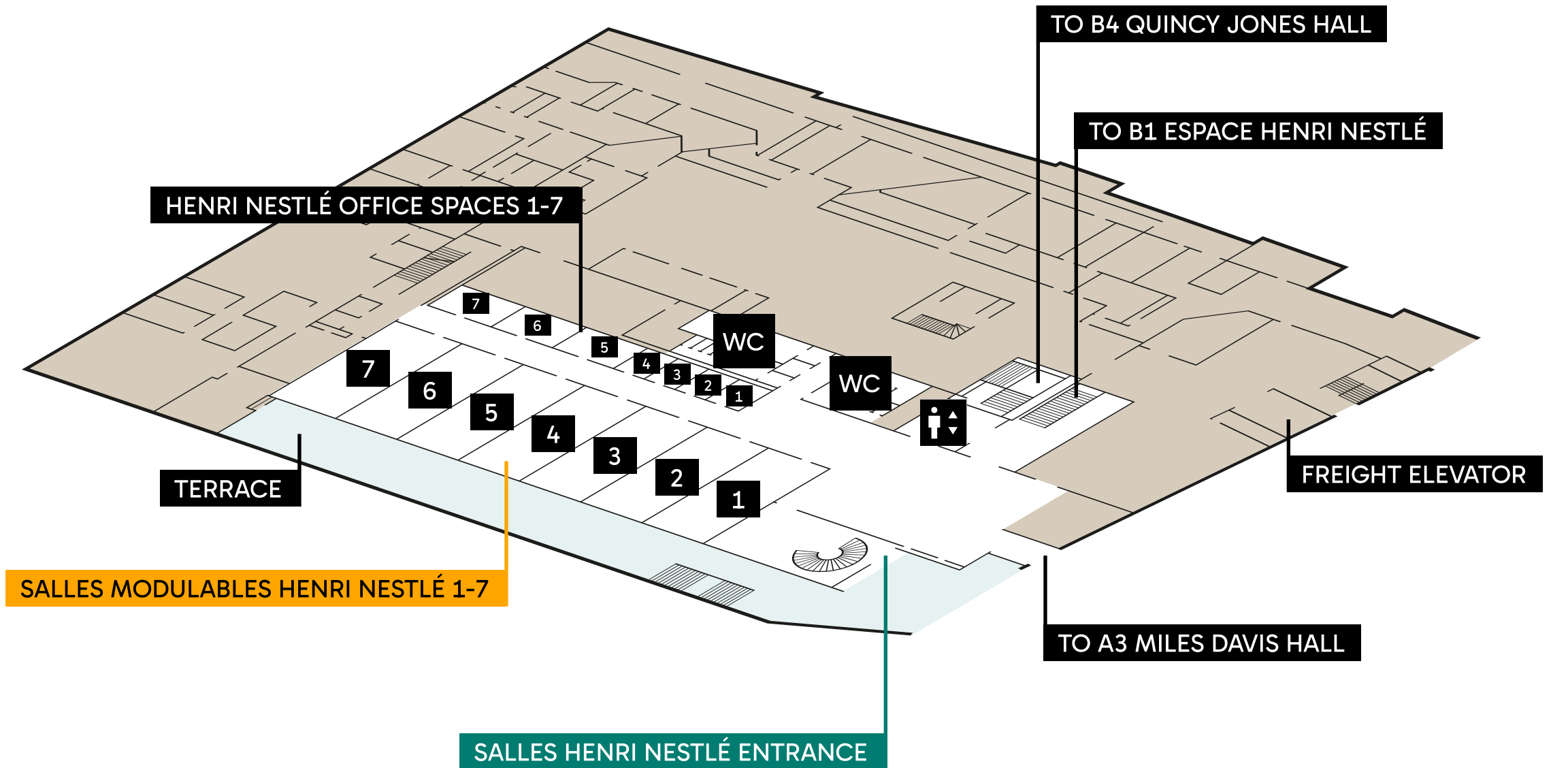

■ Outdoor areas (terraces, balconies) ■ Gap on the lower floor ■ Zone 2M2C (offices, technical facilities, storage)

Like a multi-part composition, this space plays on harmonies and variations.

Its seven modular rooms allow for any configuration: from a large gathering to a series of intimate lounges, depending on the pace of your event.

The 375 m² foyer, in turn, becomes a space for improvisation: breakout sessions, networking or pop-up exhibitions – it adapts to your rhythm.

And when it's time to take a breather, the adjoining terrace, bathed in light and opening out onto the lake and the Alps, offers an inspiring respite, a pause in chiaroscuro, suspended between nature and creativity.

TECHNICAL SPECIFICATIONS

 Level 3 Stravinski Building

 **Surface area:** 887 m²

 **Modular space:** 7 salles de 73m² chacune

 **Ceiling height:** 240 - 260 cm

 **Flooring:** pvc

 **Floor load capacity:** 400 kg/m²

 Lift

 PRM access

 **Freight elevators:** 1

1 Max 6T, loading dock access (Stravinski Building)

 WiFi on demand

 Heating, ventilation, air conditioning

 Dynamic signage

 Natural daylight

CAPACITIES

 **Theatre:** 48 - 200

 **U-Shape:** 27 - 70

 **Classroom:** 20 - 100

 **Cabaret:** 30 - 115

 **Banquet:** 50 - 400

 **Cocktail:** 60 - 400

 **Concert:** /

 **Classroom:** 887 m²

DRESSING ROOMS & OFFICES

B3 7 offices (9-19m²)

TERRACE

 **Terrace area:** 298 m²

 **Ceiling height:** 240 > 280 cm

 **Capacities (cocktail):** 230

B4

QUINCY JONES HALL

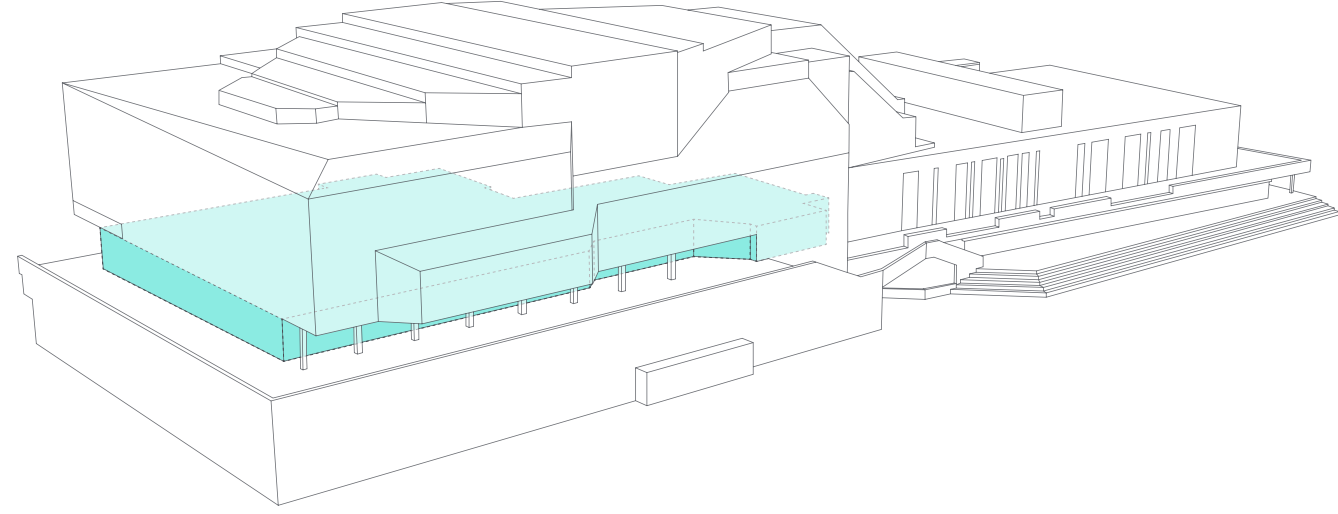

B4

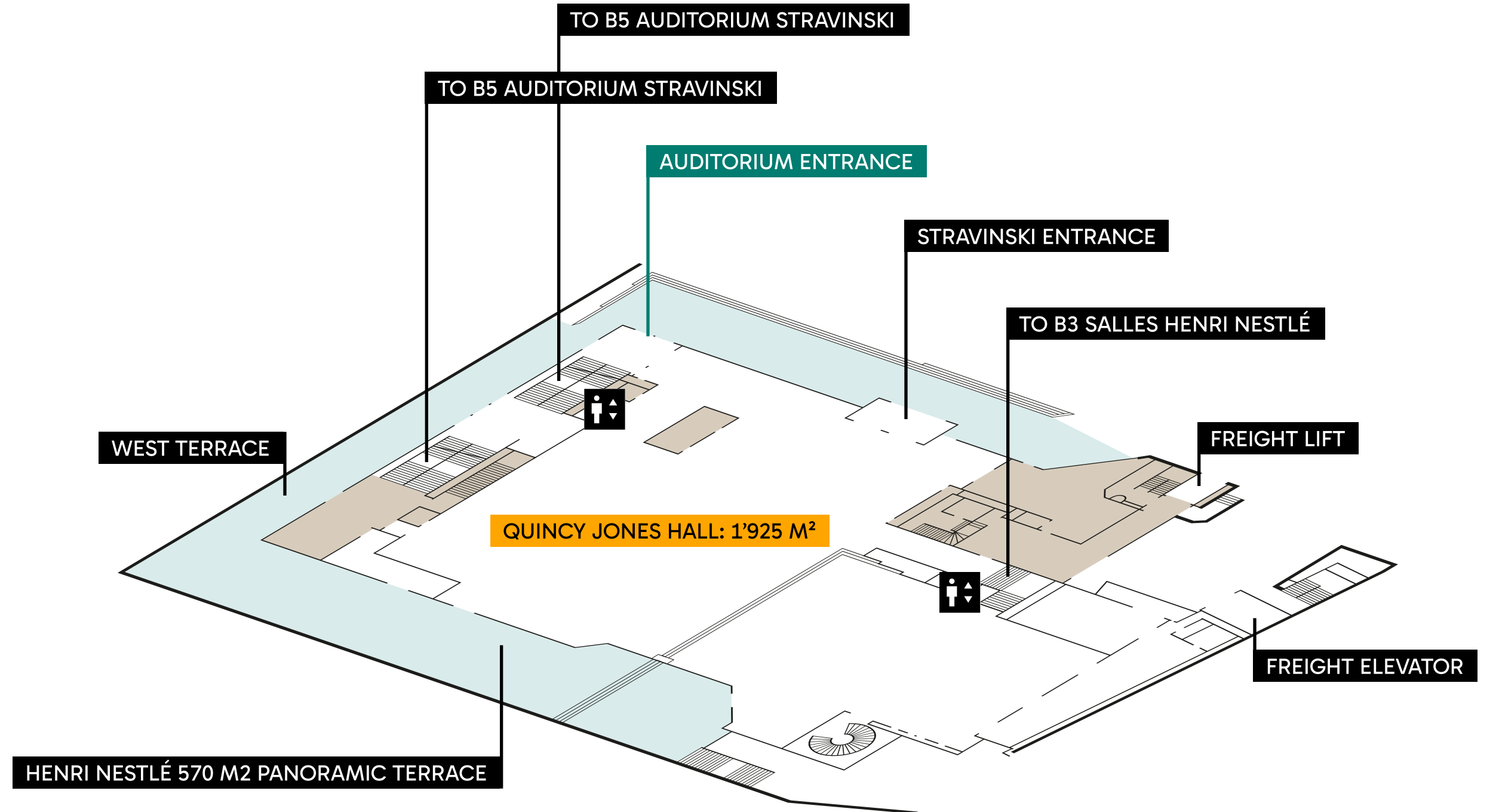

■ Outdoor areas (terraces, balconies) ■ Gap on the lower floor ■ Zone 2M2C (offices, technical facilities, storage)

Just as Quincy Jones produced legendary albums that transcend genres, the Quincy Jones Hall masterfully blends the art of event production.

A venue where every detail is perfectly orchestrated, transforming each event into an iconic moment.

The immense adjoining terrace becomes your panoramic stage, offering a breathtaking backdrop over the lake and the Alps — a setting worthy of a legendary album cover.

The Quincy Jones Hall plays every register: flexible staging, natural daylight, and panoramic views create the perfect environment for concerts, conferences, plenary sessions, gala dinners, and more.

TECHNICAL SPECIFICATIONS

 Level 4 Stravinski Building

 **Surface area:** 1,924 m²

 **Ceiling height:** upper 390 cm / lower 440 cm

 **Flooring:** resin concrete

 **Floor load capacity:** 500 kg/m²

 Lift

 PRM access

 **Freight elevators:** 2

1 Max 6T, loading dock access (Stravinski Building)

2 Max 4T, road access (Stravinski Building)

 Direct access from the street

 WiFi on demand

 Heating, ventilation, air conditioning

 Dynamic signage

CAPACITIES

 **Theatre:** /

 **U-Shape:** /

 **Classroom:** /

 **Cabaret:** /

 **Banquet:** 800

 **Cocktail:** 1,500

 **Concert:** /

 **Exhibition:** 1,924 m²

TERRACE

 **Terrace area:** 576 m²

 **Ceiling height:** 390 > 440 cm

 **Capacities (cocktail):** 460

B5-B6-B8

STRAVINSKI AUDITORIUM

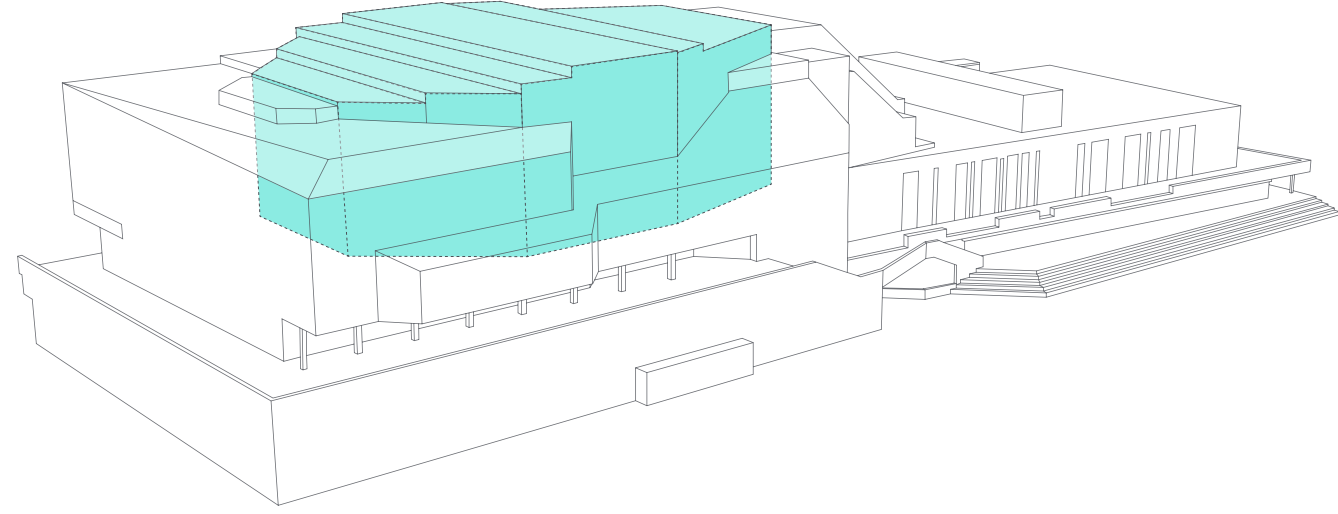

B:8

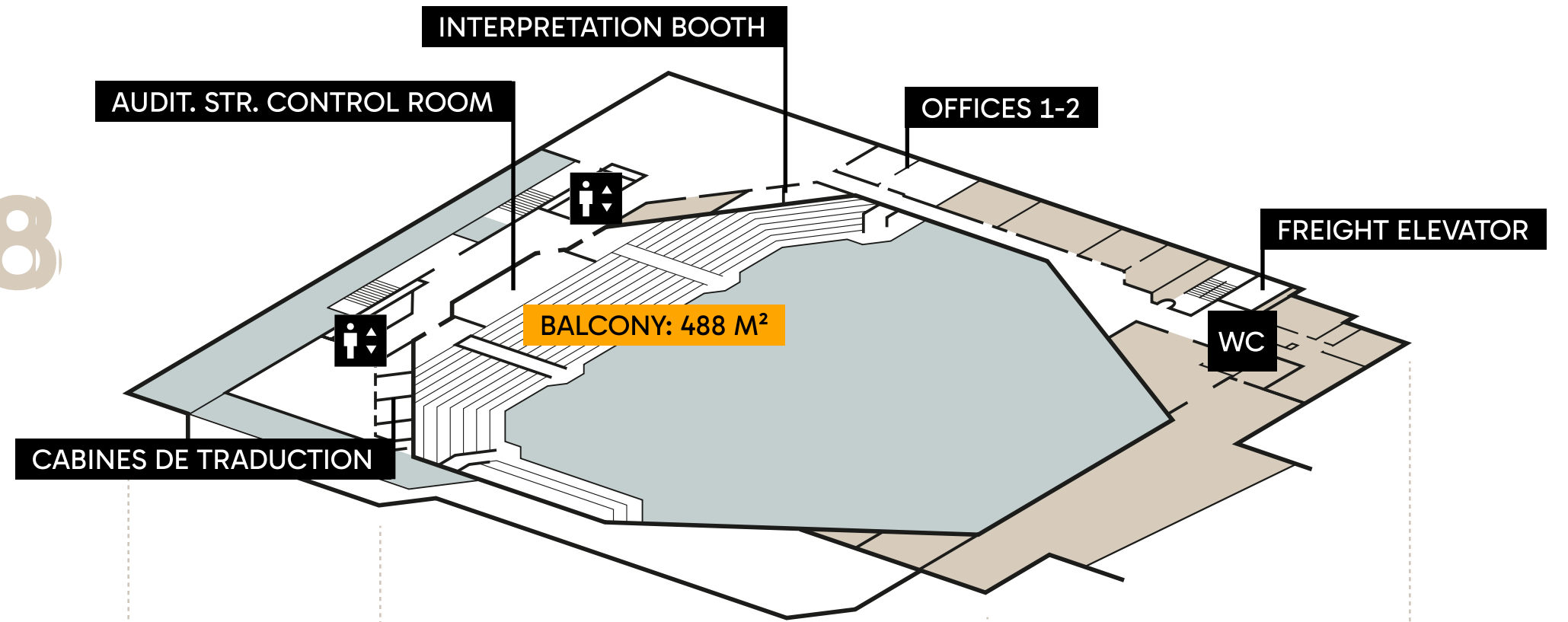

B:6

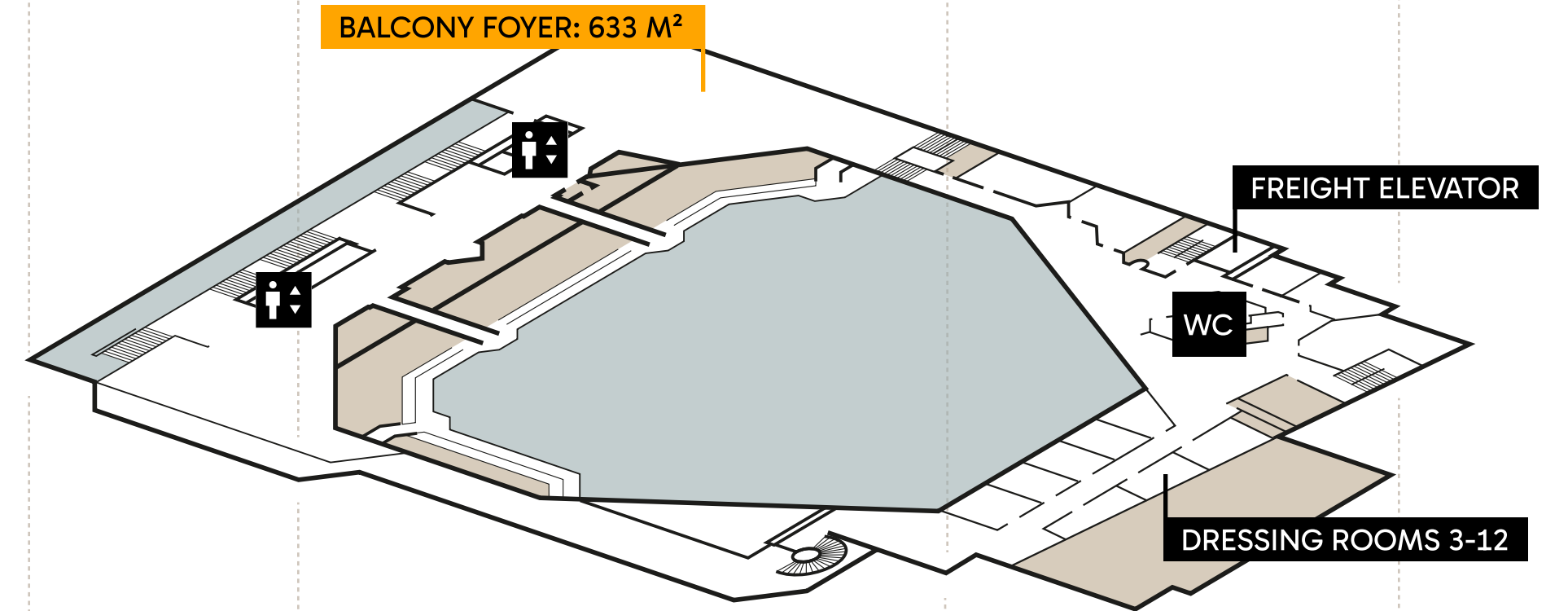

B:5

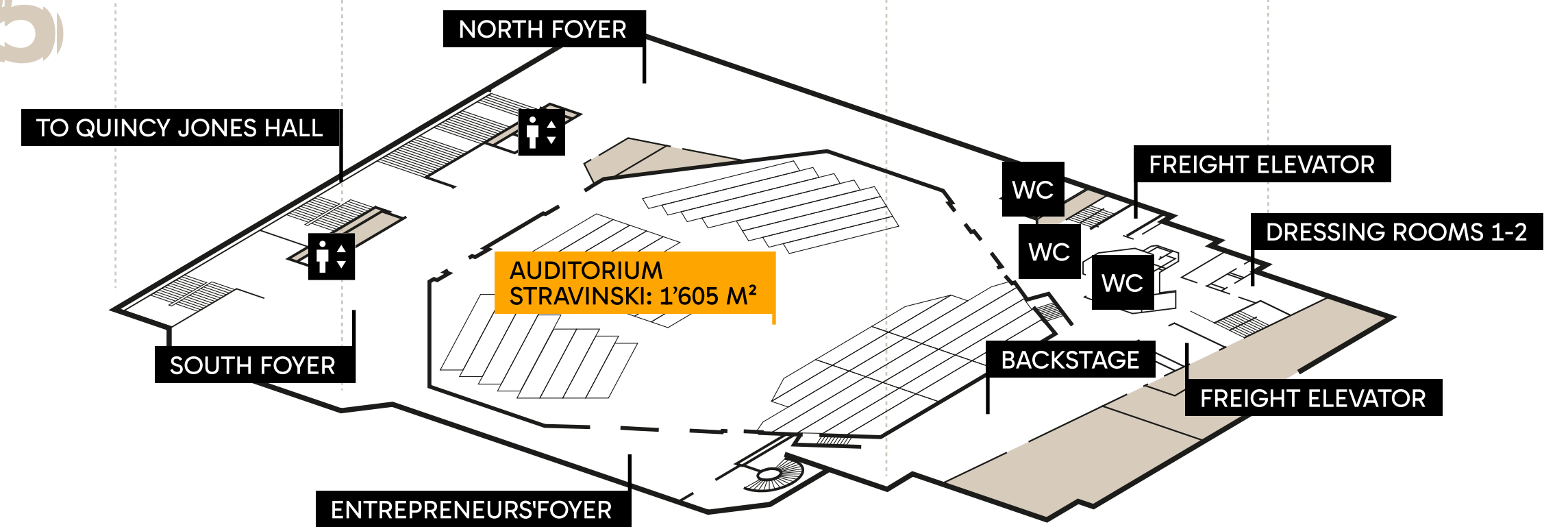

■ Outdoor areas (terraces, balconies) ■ Gap on the lower floor ■ Zone 2M2C (offices, technical facilities, storage)

The Stravinski Auditorium is the beating heart of 2M2C, paying tribute to Igor Stravinski (1882–1971), one of the major figures of 20th-century music, who composed The Rite of Spring on the Riviera — revolutionising the codes of music and dance.

The design of the Auditorium reflects Stravinski's innovative spirit: a space where tradition and modernity meet in an architecture that evokes movement and harmony.

Its remarkable beauty is expressed through the elegance of noble materials, notably precious woods that line the hall and create an atmosphere that is both warm and prestigious.

Designed for comfort and excellence, the Auditorium offers exceptional seating quality and unique modularity thanks to hydraulic platforms that allow configurations to be adapted according to needs: symphonic concerts, gala dinners, conferences, or hybrid events.

This emblematic space of 2M2C perpetuates the memory of an extraordinary artist while affirming Montreux's identity as a crossroads of innovation and internationally renowned artistic excellence.

TECHNICAL SPECIFICATIONS

 Level 5-6-8 Stravinski Building

 **Surface area:** 1,604 m²

 **Ceiling height:** 390 / 800 cm

 **Balcony height:** 410 cm

 Lift

 PRM access

 **Freight elevators:** 2

- 1 Max 6T, loading dock access (Stravinski Building)
- 2 Max 4T, road access (Stravinski Building)

 Standard lighting and natural daylight in foyers

 Spectacular view

 WiFi on demand

 Heating, ventilation, air conditioning

 Dynamic signage

CAPACITIES

 **Theatre:** 1,800

 **U-Shape:** /

 **Classroom:** 600

 **Cabaret:** 580

 **Banquet:** 800

 **Cocktail:** 1,500

 **Concert:** 4,000

 **Exhibition:** /

DRESSING ROOMS & OFFICES

B5 2 dressing rooms (11-25m²)

B6 2 offices approx. 30m²
11 dressing rooms (10-46m²)

B8 2 offices (15-22m²)
6 interpretation booths

A luminous foyer with spectacular views and a 13-metre-long bar forms the vibrant heart of the venue.

A customisable digital screen adapts to all staging concepts and event requirements.

On the south side, the space opens onto a breathtaking panoramic view where lake and mountains merge in a living scenery bathed in natural daylight.

On the north side, a modular, bright and welcoming environment offers total flexibility to create tailor-made atmospheres — from the most intimate to the most spectacular.

TECHNICAL SPECIFICATIONS

 Level 5 Stravinski Building

 **Surface area:** 820 m²

 **Ceiling height:** 250-400 cm²

 **Flooring:** tiled

 **Floor load capacity:** 500 kg/m²

 Lift

 PRM access

 **Freight elevators:** 2

1 Max 6T, loading dock access (Stravinski Building)

2 Max 4T, road access (Stravinski Building)

 Natural daylight

 WiFi on demand

 Heating, ventilation, air conditioning

 Dynamic signage

CAPACITIES

 **Theatre:** /

 **U-Shape:** /

 **Classroom:** /

 **Cabaret:** /

 **Banquet:** 300

 **Cocktail:** 650

 **Concert:** /

 **Exhibition:** 820 m²

DRESSING ROOMS & OFFICES

B5 2 dressing rooms (11-25m²)

Contact

Centre de Congrès Montreux SA
Av. Claude-Nobs 5
1820 Montreux
Switzerland

General

+41 (0) 21 962 20 00

Events Department

+41 (0) 21 962 20 10