

# Factsheet

A1-A2

DUPLEX

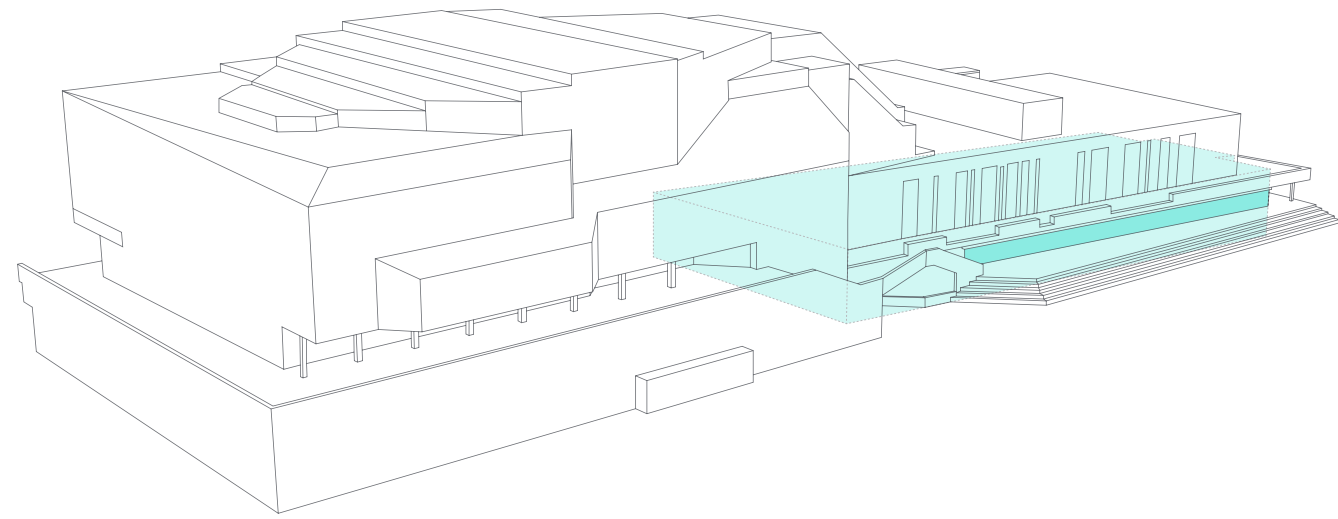

A2

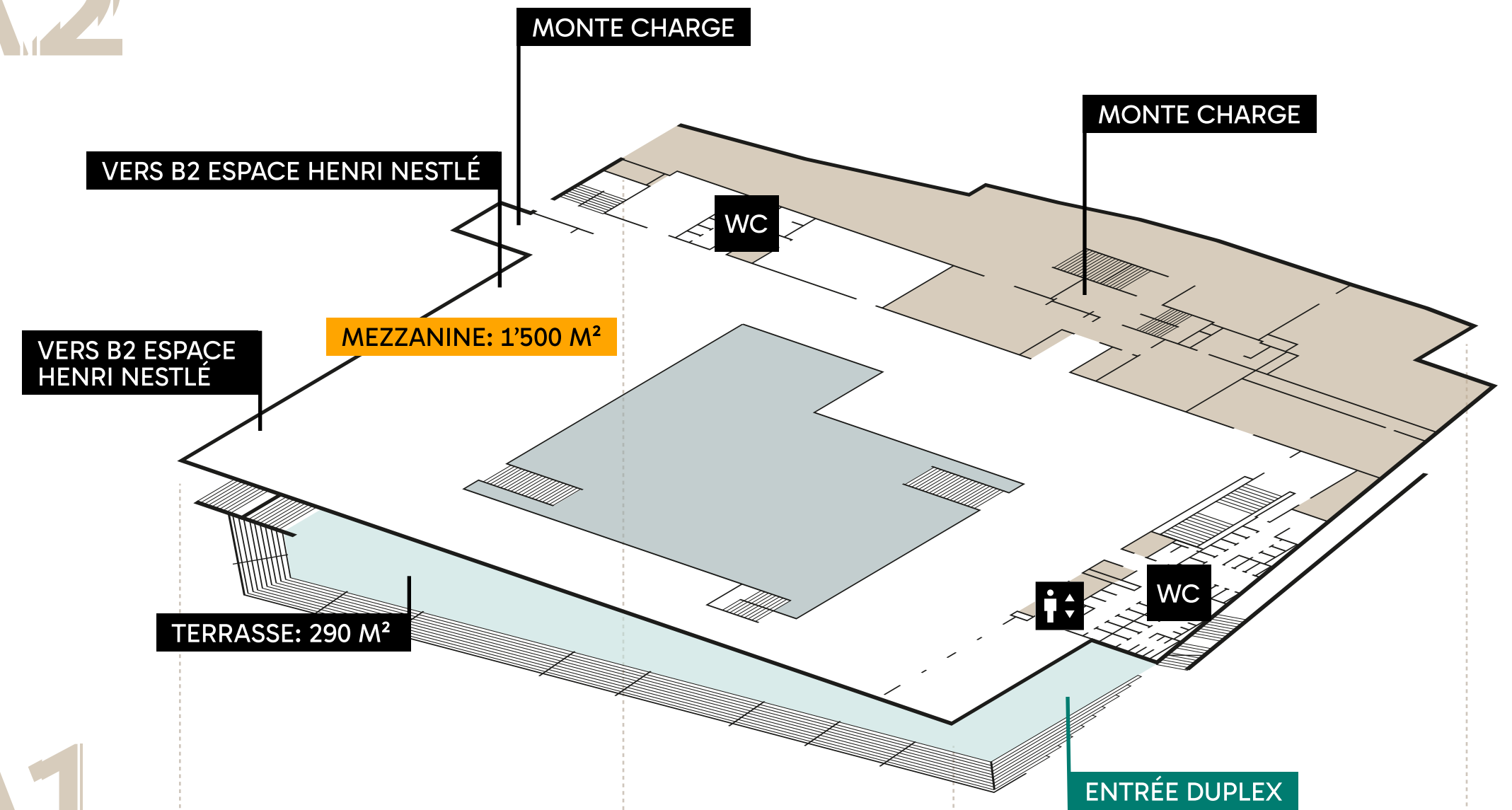

A1

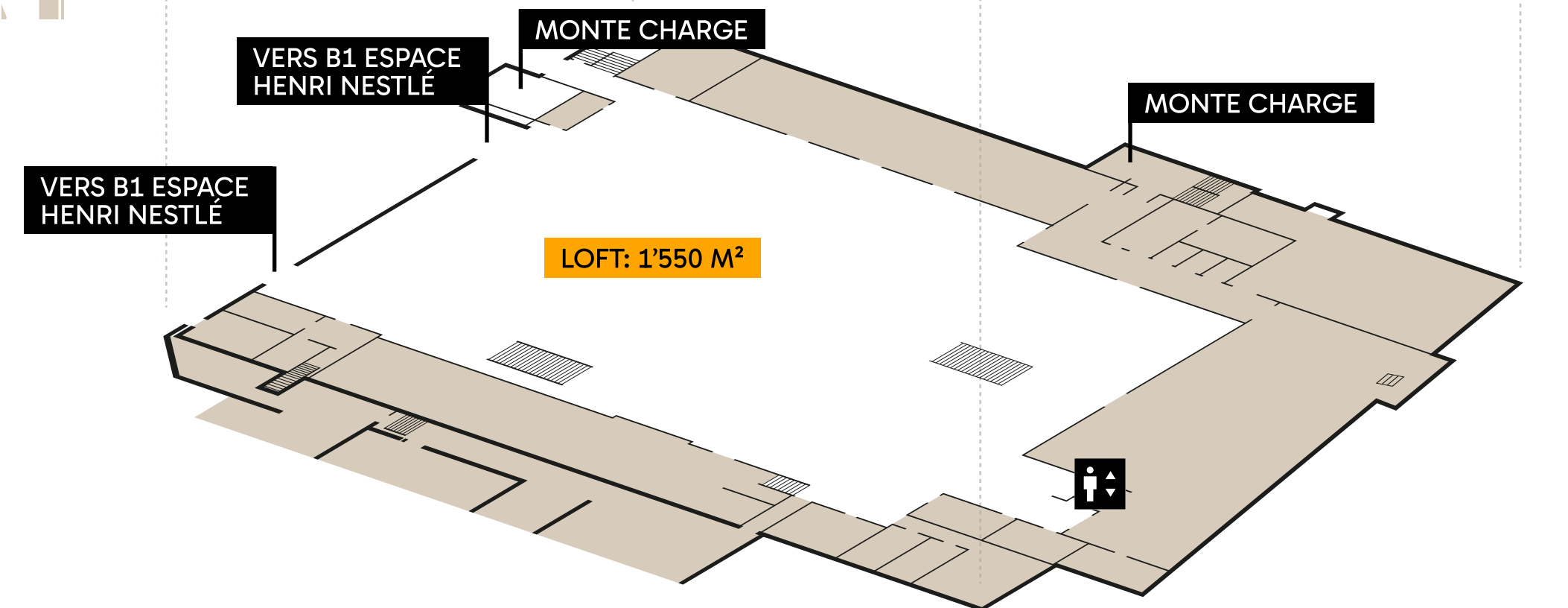

■ Zones extérieures (terrasses, balcons) ■ Vide sur étage inférieur ■ Zone 2M2C (bureaux, technique, stockage)

A1-A2

DUPLEX

### Un espace à la vue spectaculaire

Cet espace événementiel a été conçu pour inspirer et connecter, le DUPLEX se déploie sur deux niveaux, offrant une flexibilité et une modularité exceptionnelles. Ses belles baies vitrées créent un dialogue permanent entre l'intérieur et l'environnement unique de Montreux, invitant le lac et les montagnes à faire partie intégrante de chaque événement et ce également grâce à une immense terrasse de 290 m<sup>2</sup>.

### Polyvalence et coolitude

Conçu pour répondre aux exigences les plus diverses : Foires et salons professionnels, événements d'entreprise, cocktails networking, concerts DJ's, conférences internationales, présentations produits, soirées de galas et soirées de prestige.

## CARACTÉRISTIQUES

 Niveau 1-2 Bâtiment Miles Davis

 **Surface:** 3'058 m<sup>2</sup>

 **Hauteur:** 230 - 520 cm

 **Revêtement de sol:** A1 Béton brut, A2 Résine

 **Charge au sol:**  
500kg/m<sup>2</sup> au Loft,  
400kg/m<sup>2</sup> sur la Mezzanine

 Ascenseur

 Accès PMR

 **Nombre de monte charge:** 2

- 1 Max 6T, accès quai de chargement Bâtiment Stravinski
- 2 Max 3T, accès route bâtiment Miles Davis

 Accès dédié et accès direct depuis les quais et la rue

 Wifi selon besoin

 Chauffage, ventilation, climatisation

 Signalétique dynamique

 Lumière du jour

## CAPACITÉS

 **Theatre:** /

 **U-Shape:** /

 **Classroom:** /

 **Cabaret:** /

 **Banquet:** 840

 **Cocktail:** 840

 **Concert:** 840

 **Expo:** 3'058 m<sup>2</sup>

## TERRASSE

 **Surface terrasse:** 287 m<sup>2</sup>

 **Hauteur:** Non couvert

 **Capacité (cocktail):** 220

A3

# MILES DAVIS HALL

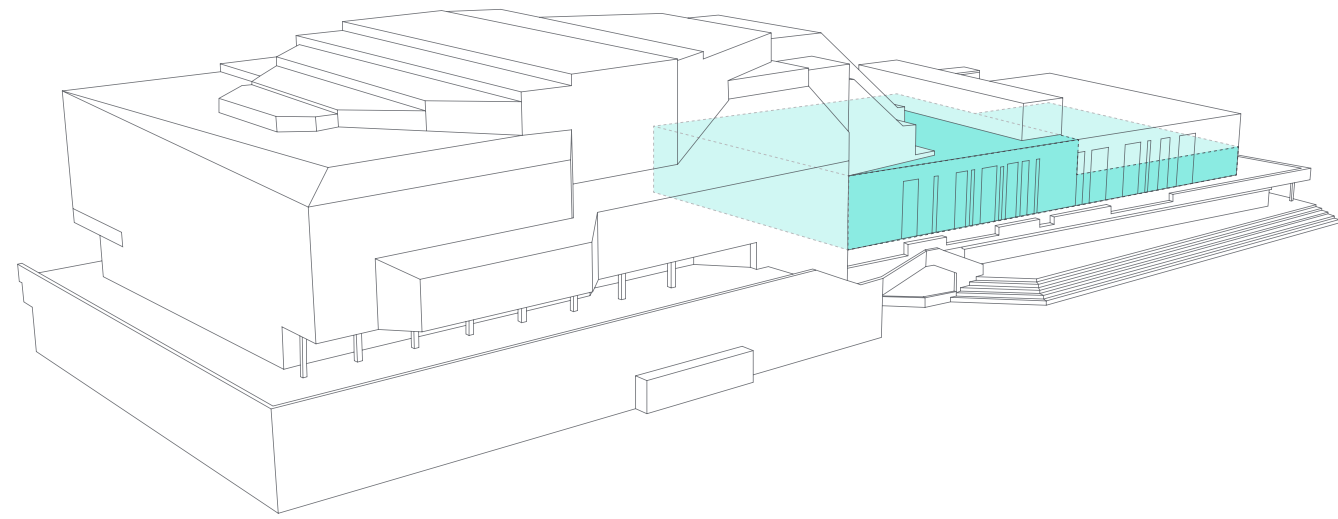

A3

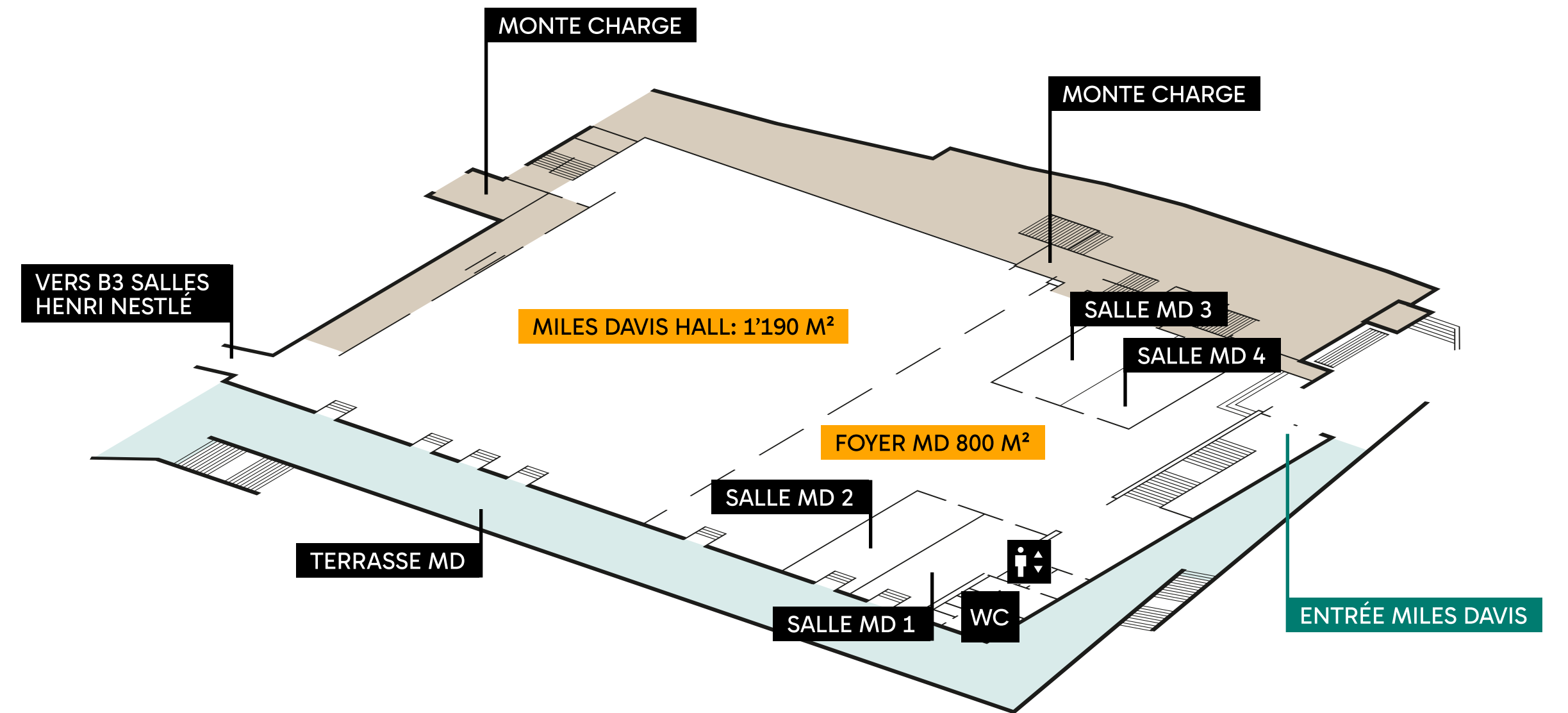

■ ZONES EXTÉRIEURES (terrasses, balcons) ■ Vide sur étage inférieur ■ Zone 2M2C (bureaux, technique, stockage)

### Un espace légendaire, une Inspiration Intemporelle

Comme Miles Davis improvisait des territoires sonores inédits, cet espace offre de véritables partitions architecturales. Directement accessible depuis la rue, ce Hall devient un instrument où toutes les compositions sont possibles; à chaque événement une performance unique. À l'image du jazz de Miles, cet espace est un territoire de liberté.

La lumière naturelle joue comme un accompagnement subtil, le panorama du lac et des Alpes formant un chœur visuel permanent.

### Accords Communs

#### (Miles Davis Hall et Miles Davis Hall Supérieur)

Que ce soit dans le Miles Davis Hall ou son espace Supérieur, vous bénéficierez d'une orchestration parfaite :

Tempo modulable des espaces, arrangements événementiels flexibles, éclairage naturel en contrepoint, vue panoramique comme un grand standard, connexions techniques en parfaite harmonie.

### CARACTÉRISTIQUES

 Niveau 3 Bâtiment Miles Davis (EST)

 **Surface:** 1'189 m<sup>2</sup>

 **Hauteur:** 600 cm

 **Revêtement de sol:** moquette

 **Charge au sol:** 400 kg/m<sup>2</sup>

 Ascenseur

 Accès PMR

 **Nombre de monte charge:** 2

1 Max 6T, accès quai de chargement Bâtiment Stravinski

2 Max 2T, accès route Bâtiment Miles Davis

 Accès direct depuis la rue

 Wifi selon besoin

 Chauffage, ventilation, climatisation

 Signalétique dynamique

### CAPACITÉS

 **Théâtre:** 900

 **U-Shape:** 100

 **Ecole:** 600

 **Cabaret:** 357

 **Banquet:** 680 (510 avec scène et foyer)

 **Cocktail:** 1'000 (1'680 avec foyer)

 **Concert:** 2'000

 **Expo:** 1'189 m<sup>2</sup>

### TERRASSE

 **Surface terrasse:** 535 m<sup>2</sup>

 **Hauteur:** Non couvert

 **Capacité (cocktail):** 420

Le foyer du Miles Davis Hall invite à la rencontre et à l'inspiration. Doté de sa propre entrée, d'un accès direct à la terrasse et d'une vue imprenable sur le lac Léman, cet espace modulable offre un cadre intimiste.

Pris en complément du Miles Davis Hall, il devient une scène à part entière un lieu où les échanges trouvent leur rythme, où les idées improvisent leur mélodie, et où l'esprit de Miles plane encore, inspirant.

## CARACTÉRISTIQUES

-  Niveau 3 Bâtiment Miles Davis

---

-  **Surface:** 803 m<sup>2</sup>

---

-  **Surface espace modulable:** 4 salles de 60 m<sup>2</sup> chacune

---

-  **Hauteur:** 290 cm

---

-  **Revêtement de sol:** moquette

---

-  **Charge au sol:** 400 kg/m<sup>2</sup>

---

-  Ascenseur

---

-  Accès PMR

---

-  **Nombre de monte charge:** 2
  - 1 Max 6T, accès quai de chargement Bâtiment Stravinski
  - 2 Max 2T, bâtiment Miles Davis

---

-  Accès direct depuis les quais et le hall central

---

-  Prises et rails d'énergie

---

-  Electricité dans les plafonds

---

-  Possibilités d'accroches au plafond

## CARACTÉRISTIQUES (SUITE)

-  Wifi selon besoin

---

-  Chauffage, ventilation, climatisation

---

-  Signalétique dynamique

## CAPACITÉS

-  **Théâtre:** 48 - 100

---

-  **U-Shape:** 27 - 33

---

-  **Ecole:** 20 - 50

---

-  **Banquet:** Jusqu'à 400 avec foyer

---

-  **Cocktail:** Jusqu'à 700 avec foyer

---

-  **Expo:** 803 m<sup>2</sup>

## TERRASSE

-  **Surface terrasse:** 535 m<sup>2</sup>

---

-  **Hauteur:** Non couvert

---

-  **Capacité (cocktail):** 420

A4

AGORA

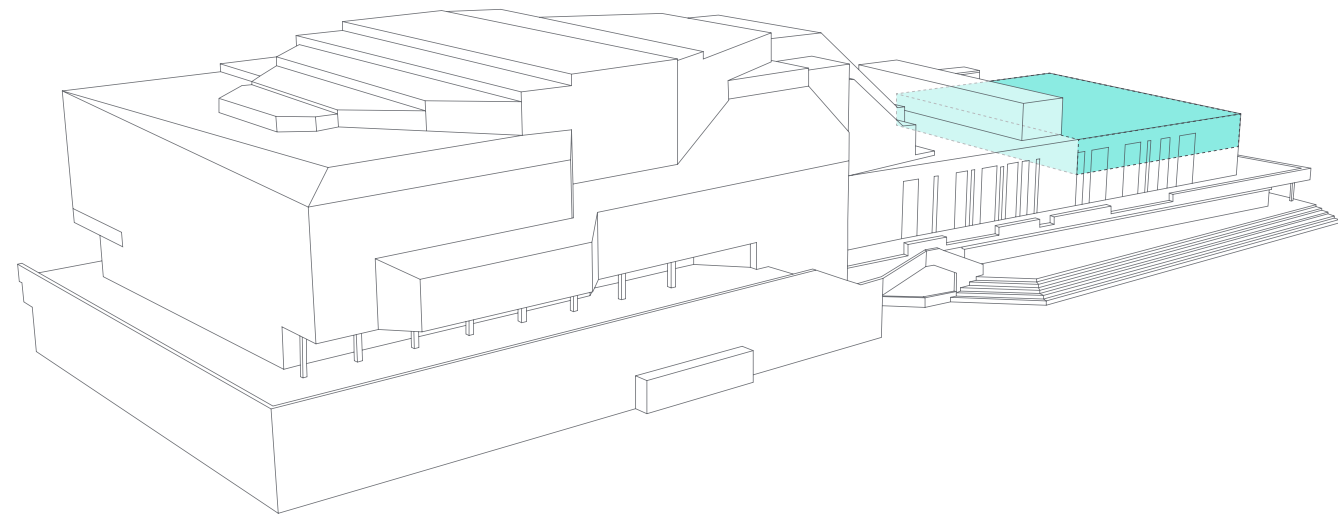

A4

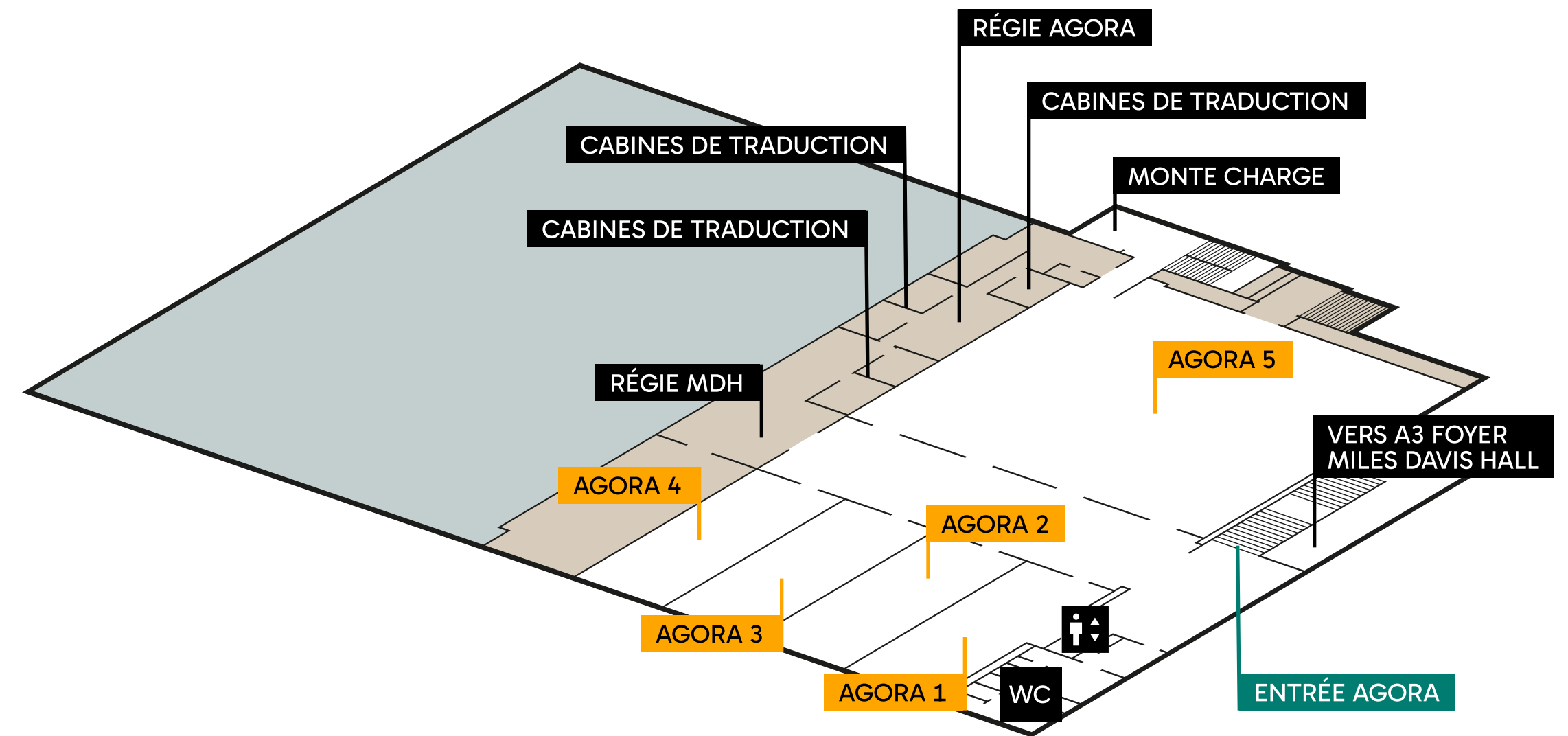

■ Zones extérieures (terrasses, balcons) ■ Vide sur étage inférieur ■ Zone 2M2C (bureaux, technique, stockage)

### Types d'événements

Tempo modulable des espaces, arrangements événementiels flexibles, éclairage naturel en contrepoint, vue panoramique comme un grand standard, connexions techniques en parfaite harmonie. Idéal pour les Conférences, Galas, Sessions de travail ou Événements corporate.

### CARACTÉRISTIQUES

-  Niveau 4 Bâtiment Miles Davis

---

-  **Surface:** 803 m<sup>2</sup>

---

-  **Hauteur:** 280 cm

---

-  **Revêtement de sol:** moquette

---

-  **Charge au sol:** 400 kg/m<sup>2</sup>

---

-  Ascenseur

---

-  Accès PMR

---

-  **Nombre de monte charge:** 1  
1 Max 2T, bâtiment Miles Davis

---

-  Wifi selon besoin

---

-  Chauffage, ventilation, climatisation

---

-  Signalétique dynamique

---

-  Lumière du jour (sauf salle Agora 5)

### CAPACITÉS

-  **Théâtre:** 48 - 300

---

-  **U-Shape:** 27 - 70

---

-  **Ecole:** 24 - 210

---

-  **Cabaret:** 30 - 175

---

-  **Banquet:** 50 - 450

---

-  **Cocktail:** 50 - 600

---

-  **Concert:** /

---

-  **Expo:** 803 m<sup>2</sup>

B1

# ESPACE HENRI NESTLÉ

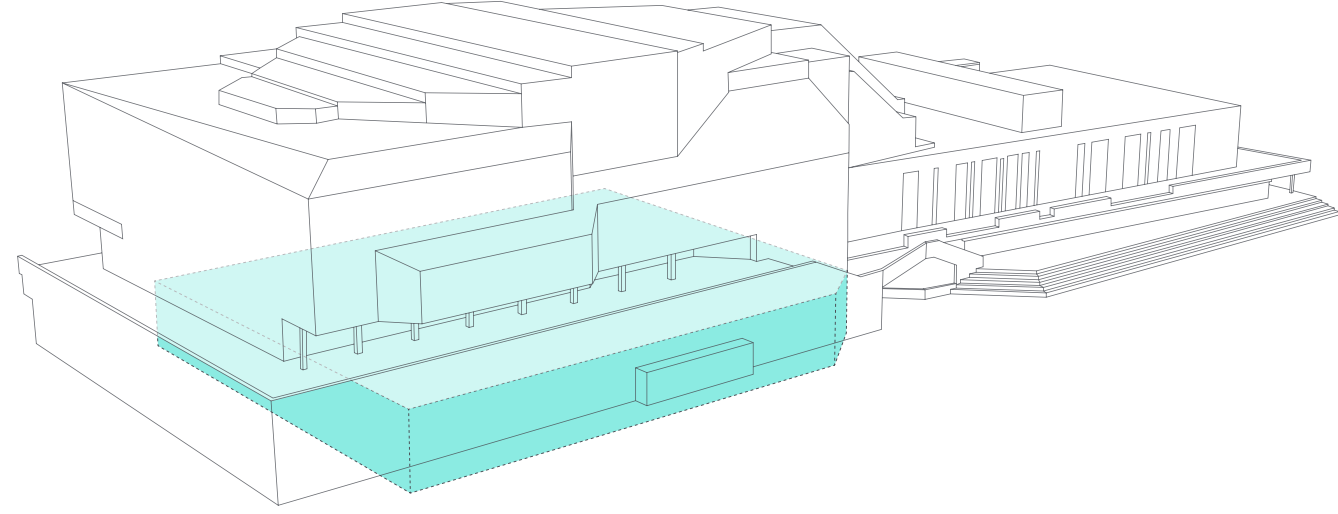

B2

B1

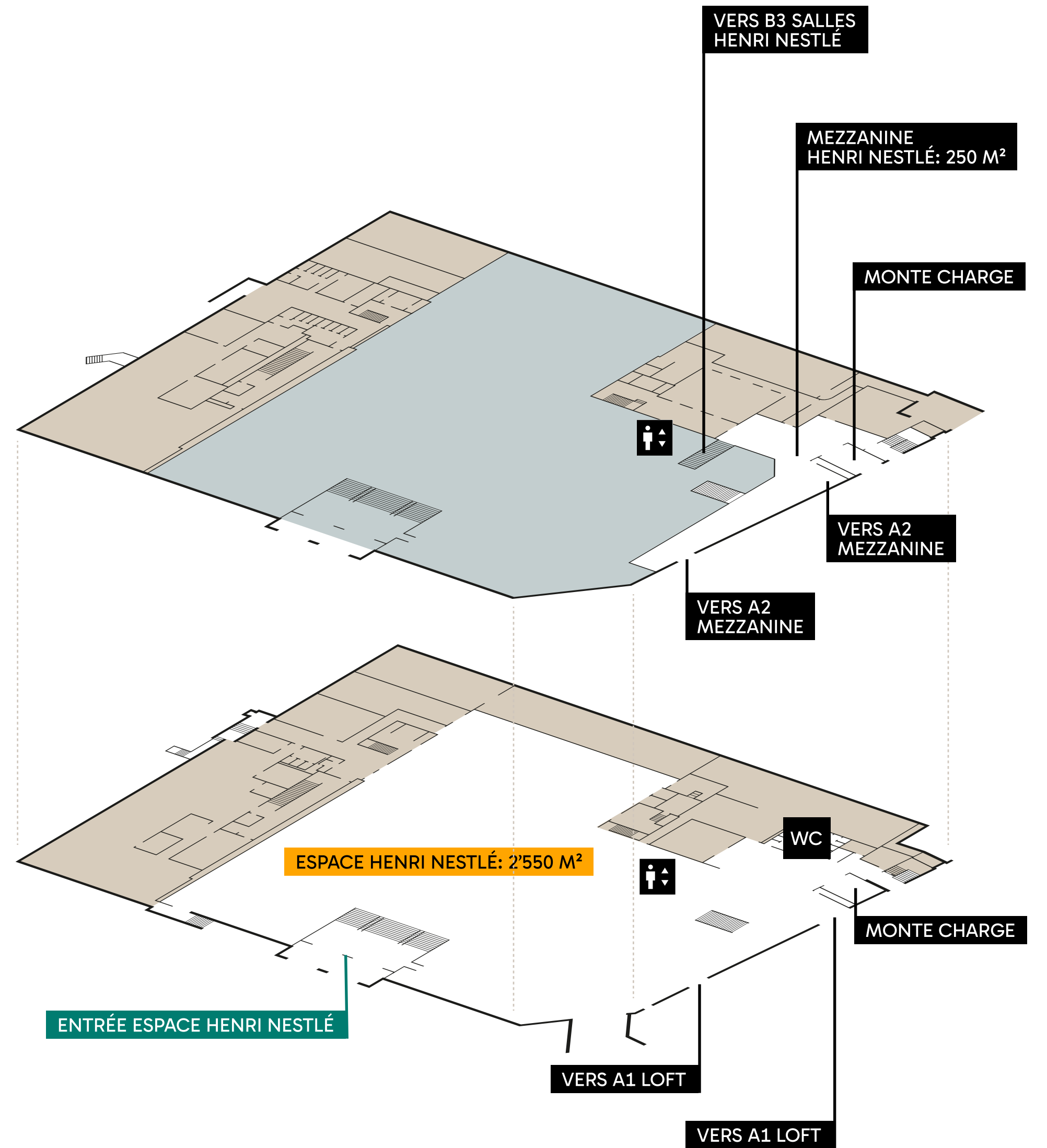

■ Zones extérieures (terrasses, balcons)
 ■ Vide sur étage inférieur
 ■ Zone 2M2C (bureaux, technique, stockage)

**L'alchimie des rencontres, un laboratoire d'événements**

Comme Henri Nestlé a transformé des ingrédients simples en innovations, l'Espace Henri Nestlé métamorphose chaque événement en expérience mémorable. Avec un accès direct depuis le quai, une vue spectaculaire, un lieu totalement ouvert à la créativité et à tous les possibles de mise en place.

**Mise en scène événementielle**

L'espace joue sur tous les tableaux : configurations modulaires, lumière naturelle et perspective panoramique aussi efficace.

Expositions avec stands, diners de gala, conférences, séminaires, projections, concerts, ...

**CARACTÉRISTIQUES**

-  Niveau 1-2 Bâtiment Stravinski

---

-  **Surface:** 2'570 m<sup>2</sup>

---

-  **Hauteur:** 240 - 470 cm

---

-  **Revêtement de sol:** Béton brut

---

-  **Charge au sol:** B1 500 kg/m<sup>2</sup>, B2 400 kg/m<sup>2</sup>

---

-  Ascenseur

---

-  Accès PMR

---

-  **Nombre de monte charge:** 1
  - 1 Max 6T, accès quai de chargement Bâtiment Stravinski

---

-  Accès direct depuis les quais

---

-  Wifi selon besoin

---

-  Chauffage, ventilation, climatisation

---

-  Signalétique dynamique

---

-  Lumière du jour

**CAPACITÉS**

-  **Théâtre:** TBC

---

-  **U-Shape:** /

---

-  **Ecole:** TBC

---

-  **Cabaret:** TBC

---

-  **Banquet:** TBC

---

-  **Cocktail:** TBC

---

-  **Concert:** TBC

---

-  **Expo:** 2'570 m<sup>2</sup>

B3

# SALLES HENRI NESTLÉ

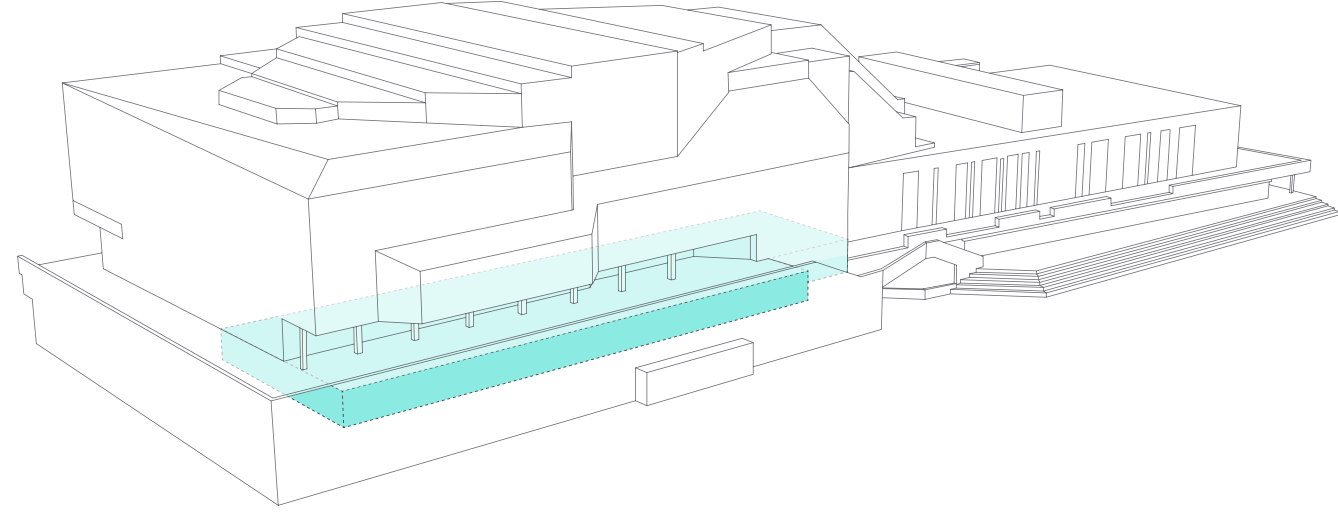

# B3

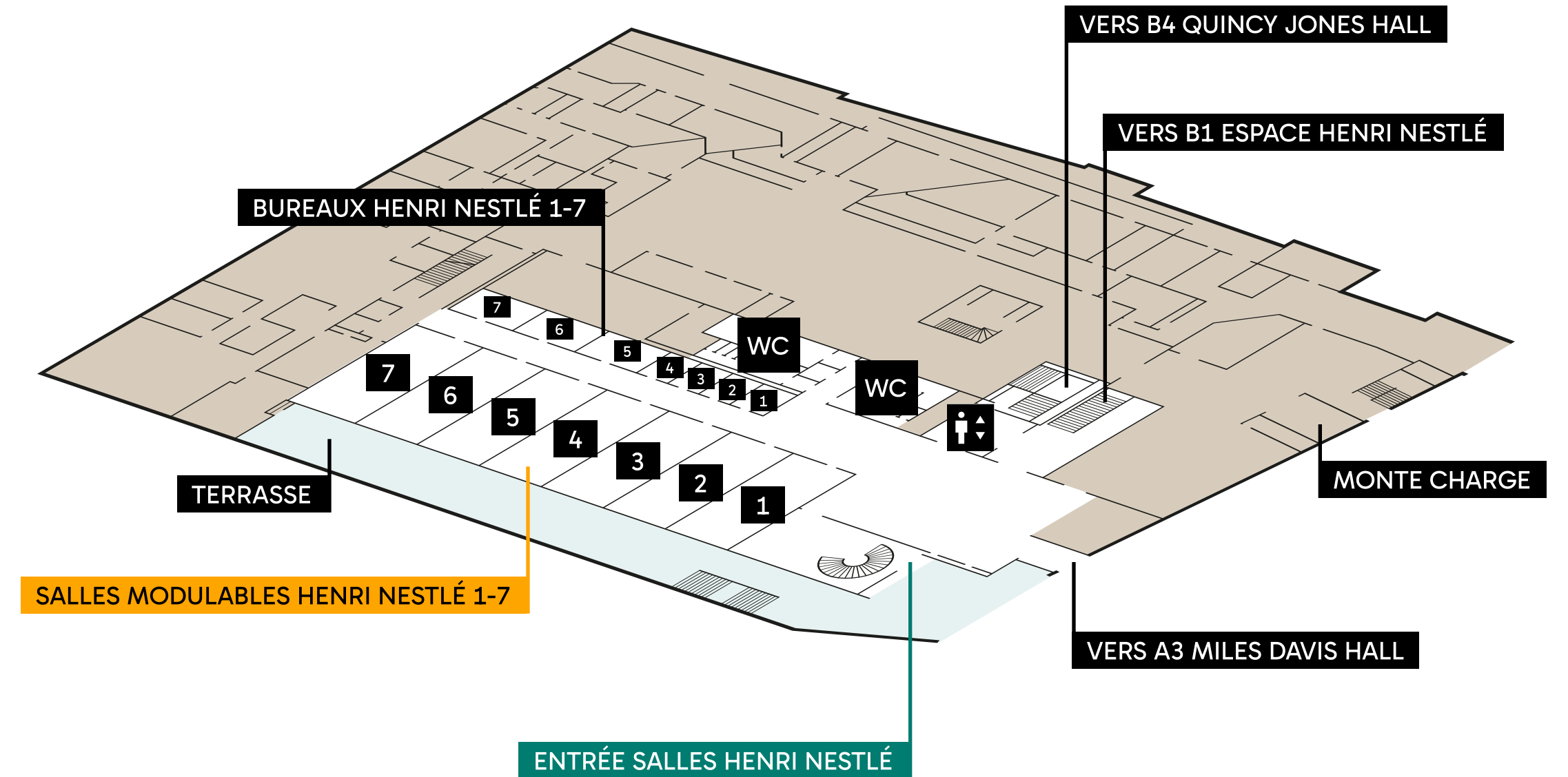

■ ZONES EXTÉRIEURES (terrasses, balcons) ■ Vide sur étage inférieur ■ Zone 2M2C (bureaux, technique, stockage)

**Comme une composition à plusieurs voix, cet espace joue sur les harmonies et les variations.**

Ses 7 salles modulables permettent toutes les orchestrations : d'un grand ensemble à une série de salons intimistes, selon le tempo de votre événement.

Le foyer de 375 m<sup>2</sup> devient à son tour un terrain d'improvisation : breakout sessions, networking ou expositions éphémères, il s'accorde à votre rythme.

Et quand vient le moment de souffler, la terrasse attenante, baignée de lumière et ouverte sur le lac et les Alpes, offre une respiration inspirante, une pause en clair-obscur, suspendue entre nature et créativité.

## CARACTÉRISTIQUES

 Niveau 3 Bâtiment Stravinski

 **Surface:** 887 m<sup>2</sup>

 **Surface espace modulable:** 7 salles de 73m<sup>2</sup> chacune

 **Hauteur:** 240 - 260 cm

 **Revêtement de sol:** pvc

 **Charge au sol:** 400 kg/m<sup>2</sup>

 Ascenseur

 Accès PMR

 **Nombre de monte charge:** 1

1 Max 6T, accès quai de chargement Bâtiment Stravinski

 Wifi selon besoin

 Chauffage, ventilation, climatisation

 Signalétique dynamique

 Lumière du jour

## CAPACITÉS

 **Théâtre:** 48 - 200

 **U-Shape:** 27 - 70

 **Ecole:** 20 - 100

 **Cabaret:** 30 - 115

 **Banquet:** 50 - 400

 **Cocktail:** 60 - 400

 **Concert:** /

 **Expo:** 887 m<sup>2</sup>

## LOGES ET BUREAUX

**B3** 7 bureaux de 9-19m<sup>2</sup>

## TERRASSE

 **Surface terrasse:** 298 m<sup>2</sup>

 **Hauteur:** 240 > 280 cm

 **Capacité (cocktail):** 230

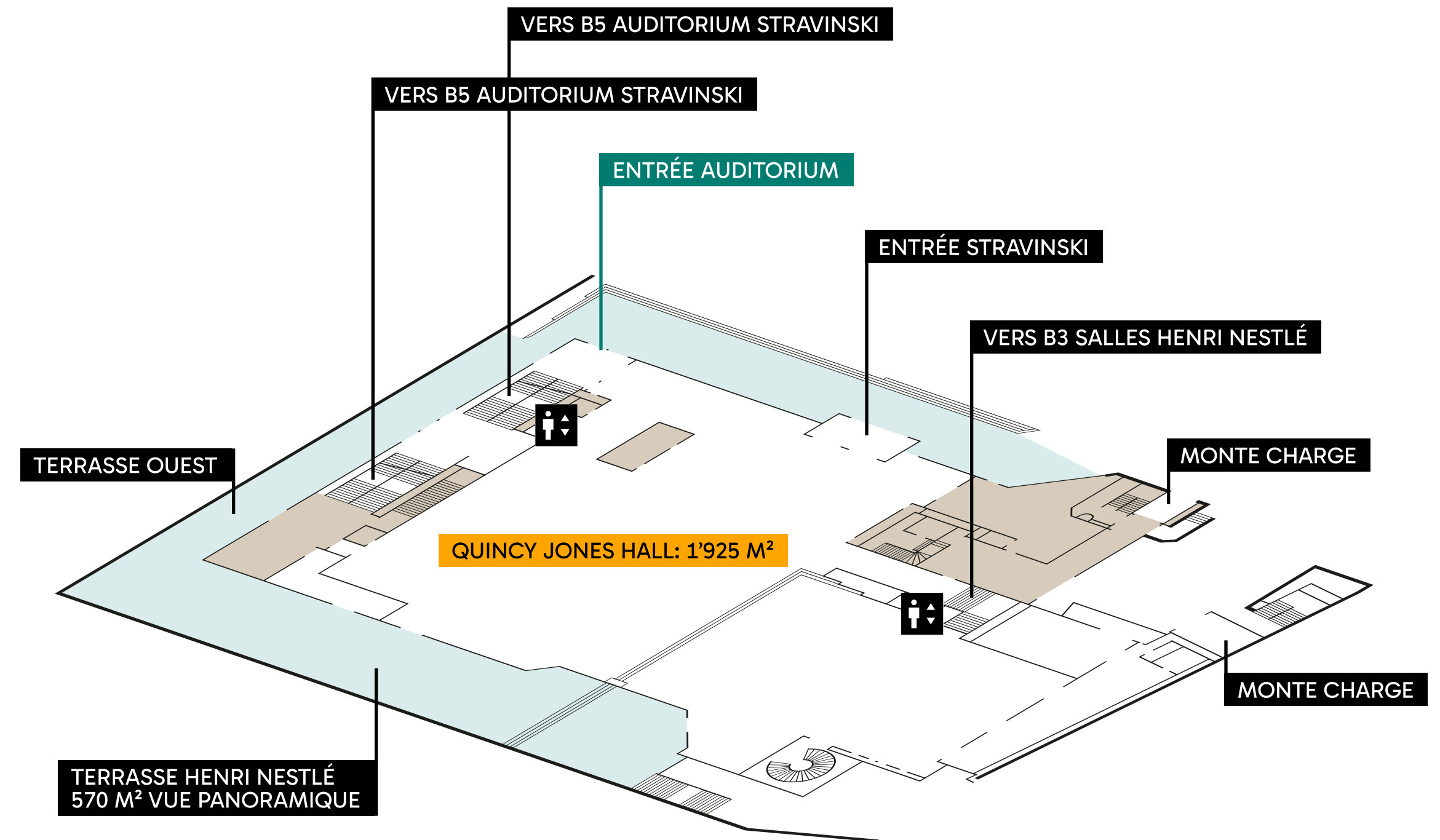
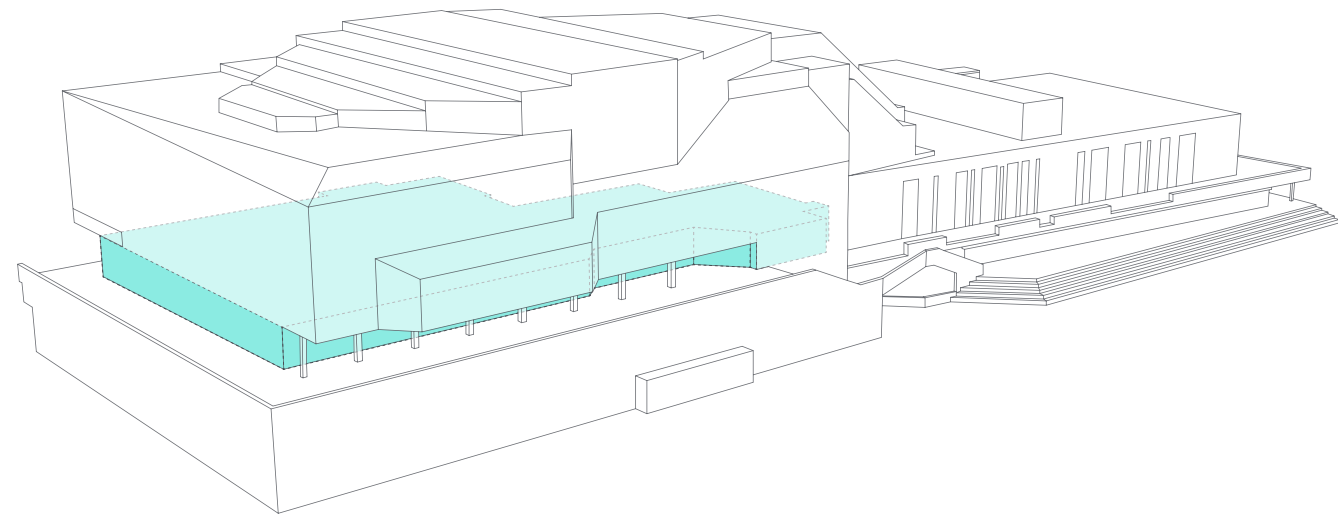

Comme Quincy Jones a produit des albums légendaires qui transcendent les genres, le Quincy Jones Hall est un espace qui mixe avec maestria l'art de l'événementiel. Un lieu où chaque détail est parfaitement orchestré. Cet espace transforme chaque événement en moment iconique.

L'immense terrasse attenante devient votre scène panoramique, offrant un backdrop à couper le souffle sur le lac et les Alpes. Un décor qui pourrait être la pochette d'un album culte. Le Quincy Jones Hall joue tous les registres : Mise en scène flexible, lumière naturelle et vue panoramique permettent des prestations tels que concerts, conférences, séances plénières, dîners de gala.

## CARACTÉRISTIQUES

 Niveau 4 Bâtiment Stravinski

 **Surface:** 1'924 m<sup>2</sup>

 **Hauteur:** sup. 390 / inf. 440 cm

 **Revêtement de sol:** Résine

 **Charge au sol:** 500 kg/m<sup>2</sup>

 Ascenseur

 Accès PMR

 **Nombre de monte charge:** 2

1 Max 6T, accès quai de chargement Bâtiment Stravinski

2 Max 4T, accès route Bâtiment Stravinski

 Accès direct depuis la rue

 Wifi selon besoin

 Chauffage, ventilation, climatisation

 Signalétique dynamique

## CAPACITÉS

 **Théâtre:** /

 **U-Shape:** /

 **Ecole:** /

 **Cabaret:** /

 **Banquet:** 800

 **Cocktail:** 1'500

 **Concert:** /

 **Expo:** 1'924 m<sup>2</sup>

## TERRASSE

 **Surface terrasse:** 576 m<sup>2</sup>

 **Hauteur:** 390 > 440 cm

 **Capacité (cocktail):** 460

B5-B6-B8

# AUDITORIUM STRAVINSKI

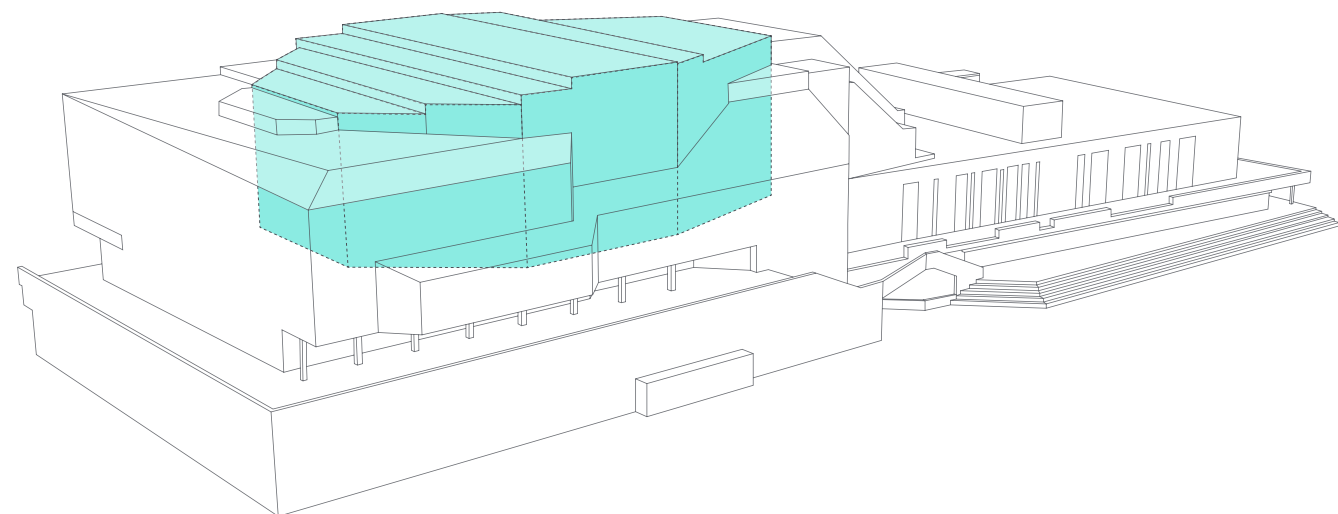

B:8

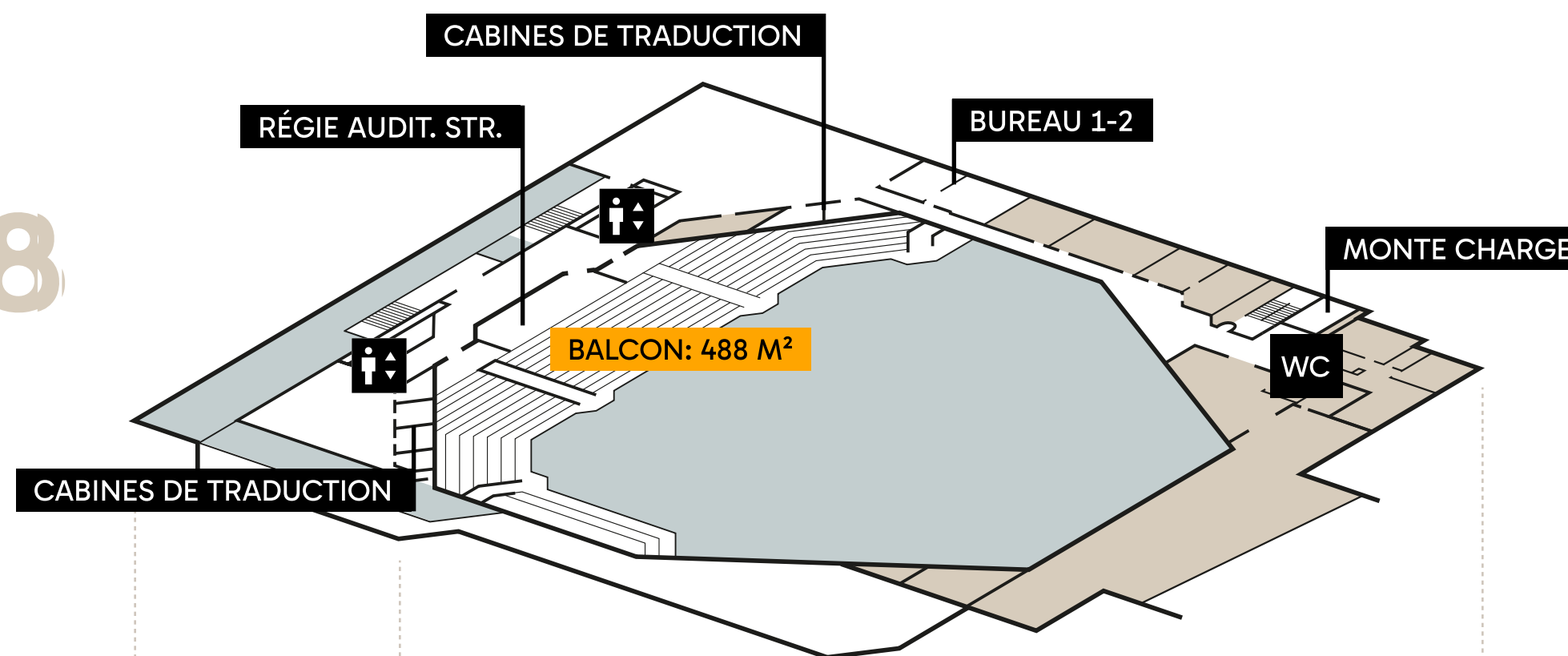

B:6

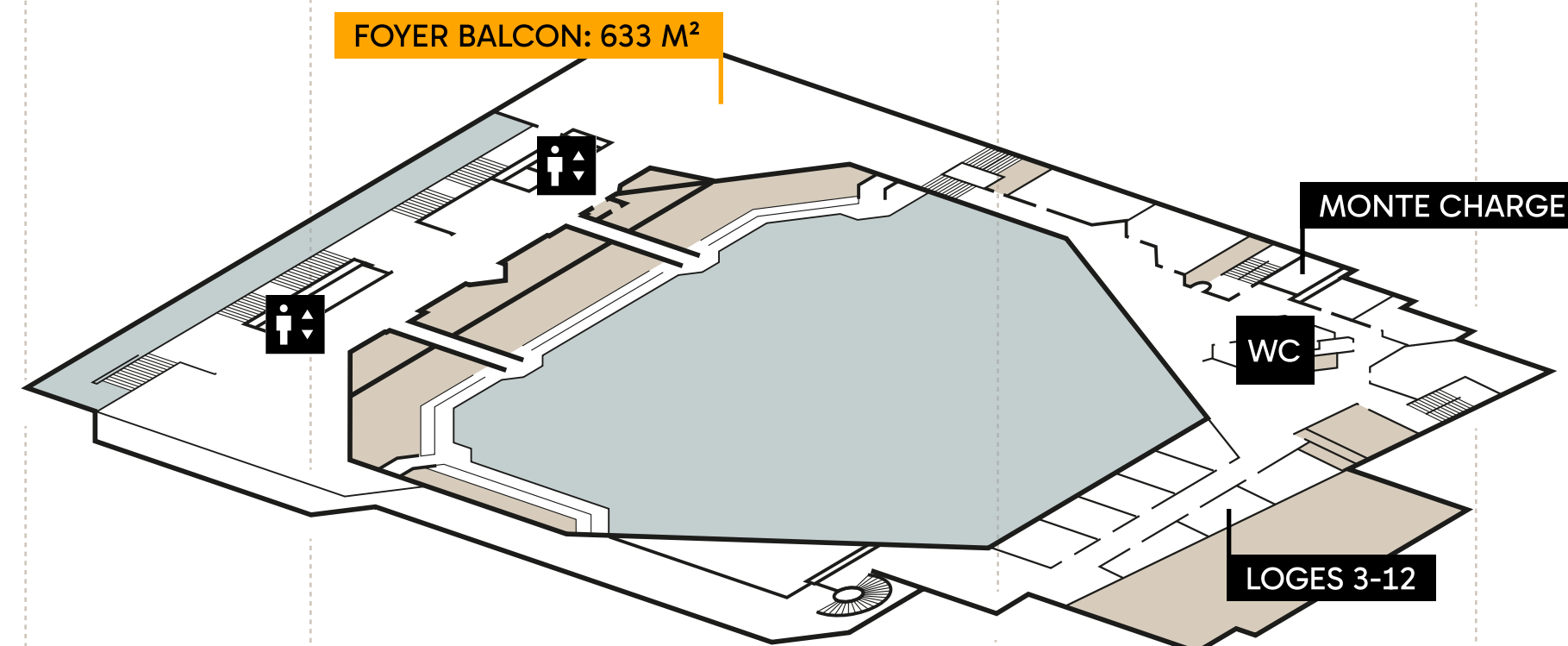

B:5

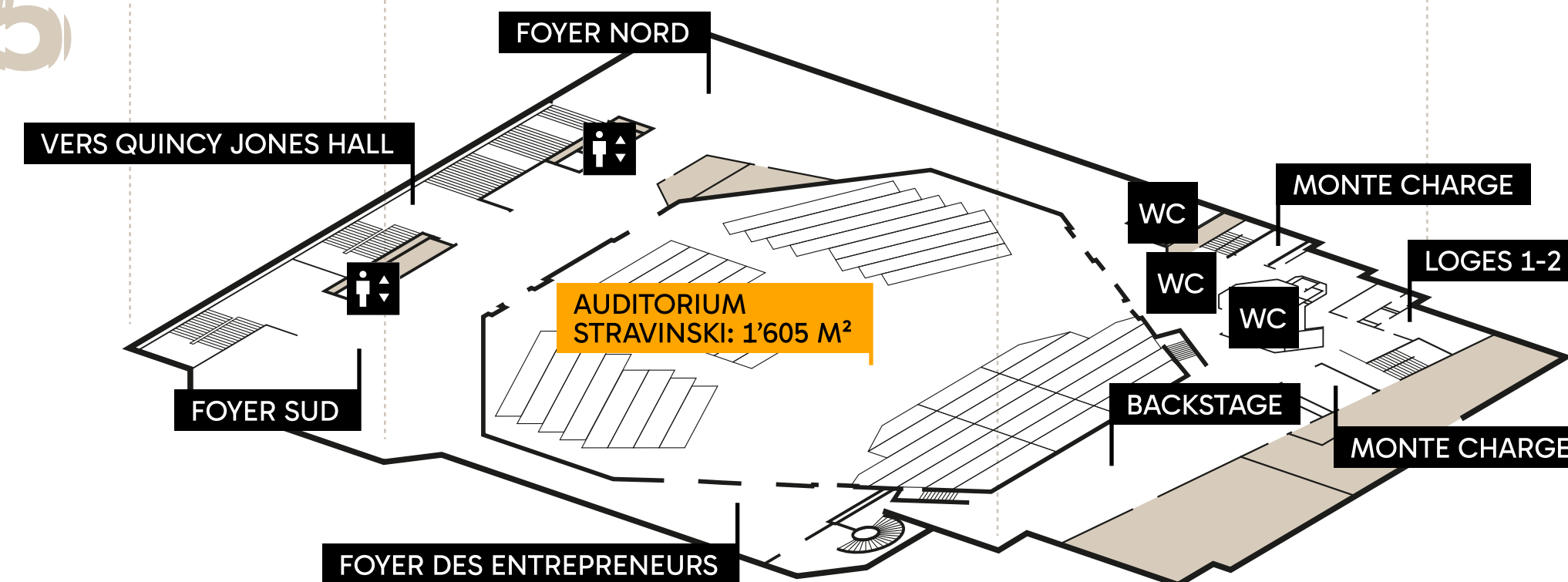

■ Zones extérieures (terrasses, balcons) ■ Vide sur étage inférieur ■ Zone 2M2C (bureaux, technique, stockage)

L'Auditorium Stravinski constitue le cœur battant du 2M2C, rendant hommage à Igor Stravinski (1882–1971), figure majeure de la musique du XXe siècle, qui composa le «Sacre du Printemps» sur la riviera, révolutionnant les codes de la musique et de la danse. La conception de l'Auditorium reflète l'esprit novateur de Stravinski : un espace où tradition et modernité se rencontrent dans une architecture évoquant mouvement et harmonie. Sa beauté remarquable s'exprime à travers l'élégance de ses matériaux nobles, notamment les bois précieux qui habillent la salle et créent une atmosphère à la fois chaleureuse et prestigieuse.

Pensé pour le confort et l'excellence, l'Auditorium offre une qualité d'assise exceptionnelle et une modularité unique grâce à ses plateaux hydrauliques permettant d'adapter la configuration selon les besoins : concerts symphoniques, dîners de gala, conférences ou événements hybrides. Cet espace emblématique du 2M2C perpétue la mémoire d'un artiste d'exception tout en affirmant l'identité de Montreux comme carrefour d'innovation et d'excellence artistique de renommée internationale.

## CARACTÉRISTIQUES

 Niveau 5-6-8 Bâtiment Stravinski

 **Surface:** 1'604 m<sup>2</sup>

 **Hauteur:** 390 / 800 cm

 **Hauteur sous balcon:** 410 cm

 Ascenseur

 Accès PMR

 **Nombre de monte charge:** 2

1 Max 6T, accès quai de chargement Bâtiment Stravinski

2 Max 4T, accès route Bâtiment Stravinski

 Eclairage standard et lumière du jour dans les foyer

 Vue spectaculaire

 Wifi selon besoin

 Chauffage, ventilation, climatisation

 Signalétique dynamique

## CAPACITÉS

 **Théâtre:** 1'800

 **U-Shape:** /

 **Ecole:** 600

 **Cabaret:** 580

 **Banquet:** 800

 **Cocktail:** 1'500

 **Concert:** 4'000

 **Expo:** /

## LOGES ET BUREAUX

**B5** 2 loges de 11-25m<sup>2</sup>

**B6** 2 bureaux de 30m<sup>2</sup> env  
11 loges de 10-46m<sup>2</sup>

**B8** 2 bureaux de 15-22m<sup>2</sup>  
6 Cabines de traduction

Un foyer lumineux avec une vue spectaculaire et un bar de 13 mètres de long forment le cœur vibrant du lieu.

Un écran digital personnalisable s'adapte à toutes les mises en scène et à tous les besoins événementiels.

Côté sud, l'espace s'ouvre sur une vue panoramique à couper le souffle : lac et montagnes s'y mêlent dans un décor vivant, baigné de lumière naturelle.

Côté nord, un environnement modulable, lumineux et accueillant, offre une flexibilité totale pour créer des ambiances sur mesure, du plus intime au plus spectaculaire.

## CARACTÉRISTIQUES

 Niveau 5 Bâtiment Stravinski

 **Surface:** 820 m<sup>2</sup>

 **Hauteur:** 250-400 cm<sup>2</sup>

 **Revêtement de sol:** Carrelage

 **Charge au sol:** 500 kg/m<sup>2</sup>

 Ascenseur

 Accès PMR

 **Nombre de monte charge:** 2

1 Max 6T, accès quai de chargement Bâtiment Stravinski

2 Max 4T, accès route Bâtiment Stravinski

 Lumière du jour

 Wifi selon besoin

 Chauffage, ventilation, climatisation

 Signalétique dynamique

## CAPACITÉS

 **Théâtre:** /

 **U-Shape:** /

 **Ecole:** /

 **Cabaret:** /

 **Banquet:** 300

 **Cocktail:** 650

 **Concert:** /

 **Expo:** 820 m<sup>2</sup>

## LOGES ET BUREAUX

**B5** 2 loges de 11-25m<sup>2</sup>

**Contact**

Centre de Congrès Montreux SA  
Av. Claude-Nobs 5  
1820 Montreux  
Suisse

**Général**

+41 (0) 21 962 20 00

**Service Evénements**

+41 (0) 21 962 20 10